



2000  
Series

Installation Manual

DUEMILA

[esbcar.com](http://esbcar.com)



[esbcar.com/2000-series](http://esbcar.com/2000-series)  
Specifications may change without notice.

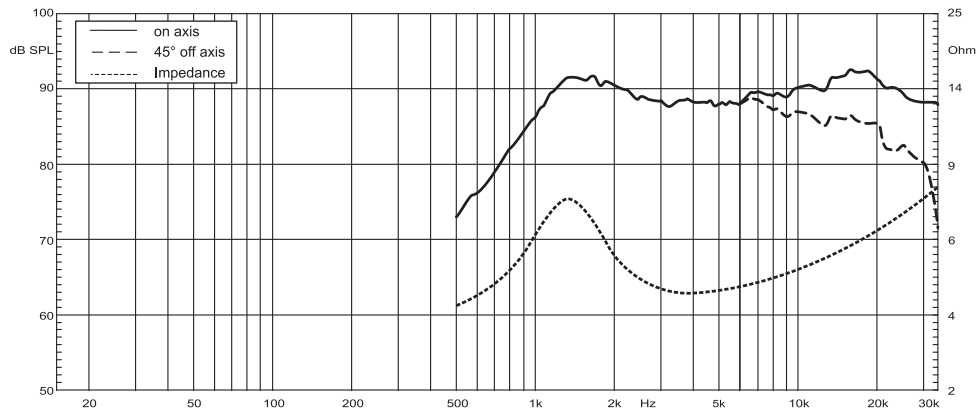

**ESB**  
AUDIO

**2.25**  
1"/25 mm Tweeter

Installation Manual

### MAIN FEATURES

- 25 mm voice coil
- Neodymium magnet N42 type
- Light vented aluminum former
- Hi Module Silk dome
- ABS housing with self damping system
- Ferrofluid cooling and damping
- Computer optimized design
- Motor metal parts CNC machined
- Under dome dB Cloth® damping
- Multi angle dash mounting cup
- Flush or free mounting system

### TECHNICAL SPECIFICATIONS

- Power handling:  
160 W peak, 50 W continuous
- Frequency response:  
1.2 - 25 KHz +/- 3dB
- Crossover cut-off:  
From 2 KHz to 3.5 KHz 12dB/Oct.  
From 2.5 KHz to 3.5 KHz 6dB/Oct.
- Sensitivity:  
89 dB SPL 1W/1m
- Size:  
Overall diameter: 47 mm  
Total Height: 20 mm  
Mounting depth: 11 mm  
Mounting hole: 40 mm

**NOTE:** Make sure that your mounting location will not cause damage to the components of your vehicle. Check for airbag system location, speaker can't be located over or close it. Never play this component without crossover, especially with high powers, this can damage it. Never play the system with amplifier in clipping or high distortion level. If use a passive crossover, use a dedicated crossover system, don't use a generic passive crossover, these are not designed for this speaker impedance and the indicated cut-off frequency may not be true.

**DUEMILA**

esbcar.com

The ESB 2.25 tweeter can be installed with different solution, this depend of car type, factory location and tweeter position or listening angle. First solution is to use the back thread hole and with M4x3 screw; use this for fix in an existing panel or use a plastic or steel bracket for fix it. Use flat head screws type. Screw it by hand with limited torque when close. Note: the max screw length must be reduce by washer if you remove the back plate. Never insert any screw over 4 mm inside back thread of tweeter motor, this can crack the magnet and damage the tweeter.

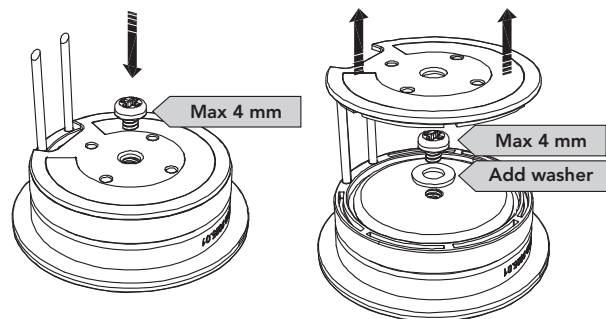

After removed the ring you can place the tweeter in a 43 mm diameter hole in a car panel (max 4 mm thickness). Place the tweeter inside the ring and push from back the fixing ring until listen the click. The outer ring can also be fixed in other ways to the car panel, for example with glue or resin, the tweeter has side hooks with which it is fixed to the ring. For similar mounting and fixing solution use the back screw to fix the metal spring.

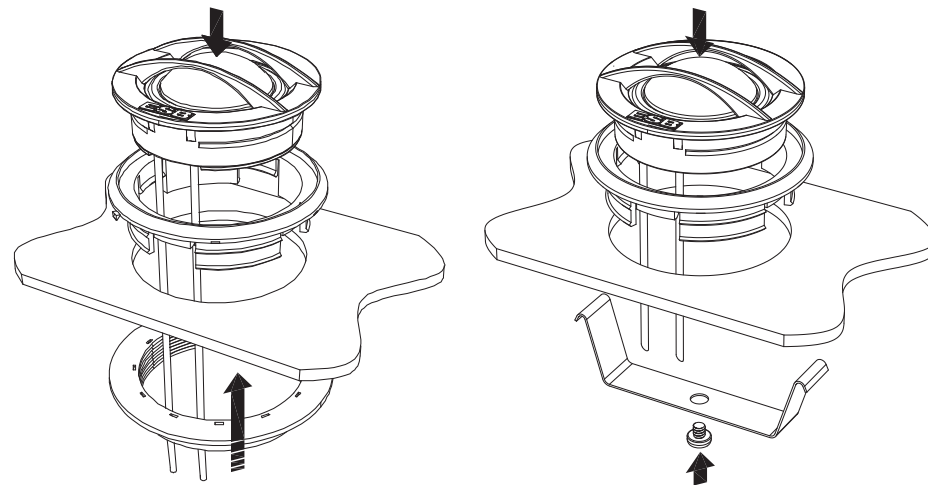

Other mounting system can be with multi holes bracket. Insert tweeter from upper side and the fixing ring from back then push all together to block the three parts. Bracket can be screwed on car factory location by side holes. There are three couple with different lengths (77, 97 and 117 mm). Cut the excess if needed. For flush mounting cut the six "bridges" that join the central ring to the side bracket of the adapter.

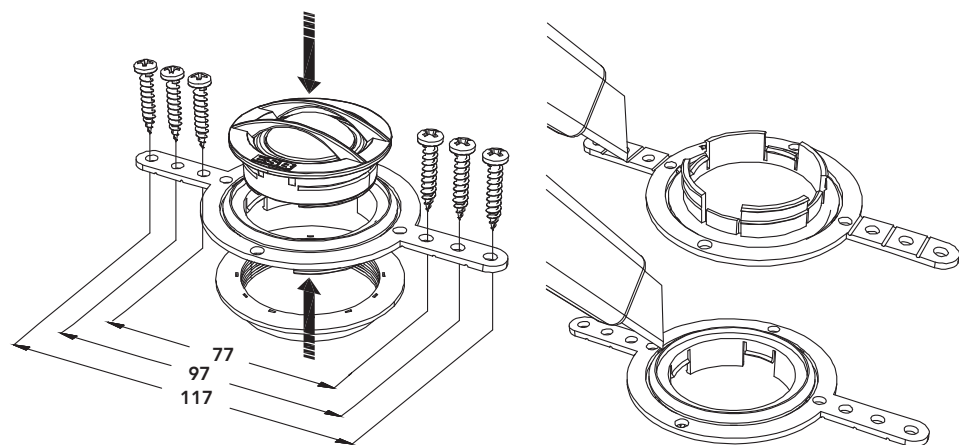

The tweeter can be mounted to a surface via the mounting cup. Choose the angle and position you prefer. Drill holes for cables and screws. After this fasten the cup with two screws. The tweeter is inserted by pressing until the click is heard. Be safe with the cables, they must be free when the tweeter is inserted into the cup.

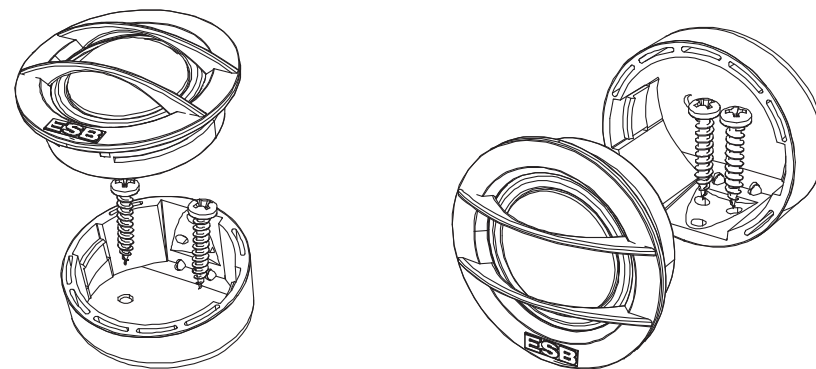

The 2.25 tweeter use a pair of soft and super flexible cable, all are black, but on terminals end there are the polarity identification by red and black insulation tubes.

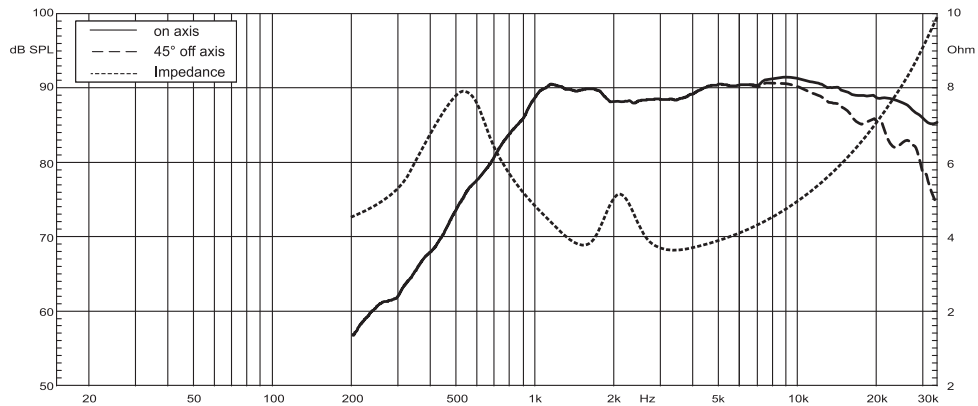

## Installation Manual

### MAIN FEATURES

- 28 mm voice coil
- Nominal diameter 32.8 mm
- Neodymium magnet N42 type
- Torcon® soft dome
- ABS housing with self damping system
- Ferrofluid cooling and damping
- Computer optimized design
- Motor metal parts CNC machined
- Under dome dB Cloth® damping
- Multi angle dash mounting cup
- Stealth mounting system adaptor

### TECHNICAL SPECIFICATIONS

- Power handling:  
180 W peak, 90 W continuous
- Frequency response:  
900 Hz - 25 KHz +/- 3dB
- Crossover cut-off:  
From 2 KHz to 3.5 KHz 12dB/Oct.  
From 2.5 KHz to 3.5 KHz 6dB/Oct.
- Sensitivity:  
91 dB SPL 1W/1m
- Overall diameter: 58 mm  
Total Height: 22 mm  
Mounting depth: 11 mm  
Mounting hole: 43 mm

**NOTE:** Make sure that your mounting location will not cause damage to the components of your vehicle. Check for airbag system location, speaker can't be located over or close it. Never play this component without crossover, especially with high powers, this can damage it. Never play the system with amplifier in clipping or high distortion level. If use a passive crossover, use a dedicated crossover system, don't use a generic passive crossover, these are not designed for this speaker impedance and the indicated cut-off frequency may not be true.

# DUEMILA

The ESB 2.28 tweeter can be installed with different solution, this depend of car type, factory location and tweeter position or listening angle. First solution is to use the back thread hole and with M4x3 screw; use this for fix in an existing panel or use a plastic or steel bracket for fix it. Use flat head screws type. Screw it by hand with limited torque when close. Note: Never insert any screw over 4 mm inside back thread of tweeter motor, this can crack the magnet and damage the tweeter.

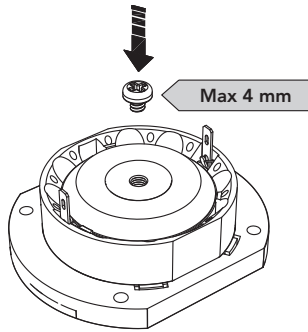

Basic mounting system is to use the four Allen screws and fix the 2.28 by the 4 mounting holes from face-plate. Similar mounting and fixing solution is to use the back screw for fix the metal spring.

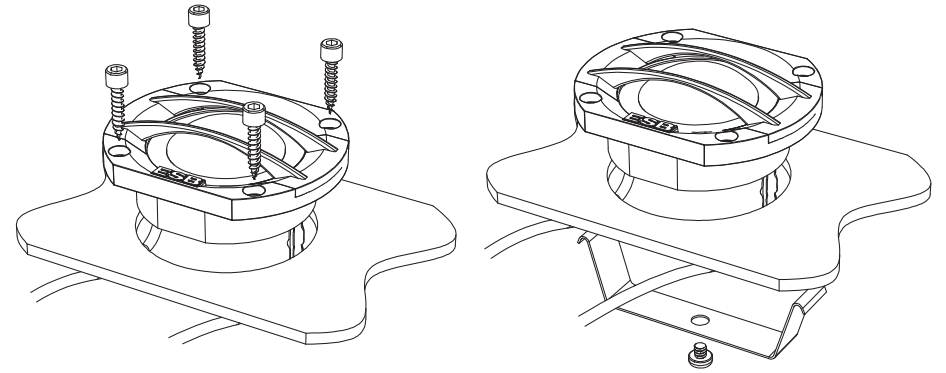

Other mounting system can be with multi holes bracket. Bracket can be screwed on car factory location by side holes. There are three couple with different lengths (77, 97 and 117 mm). Cut the excess if needed. For flush mounting cut the six "bridges" that join the central ring to the side bracket of the adapter. Insert the tweeter from upper side and then push it inside the ring.

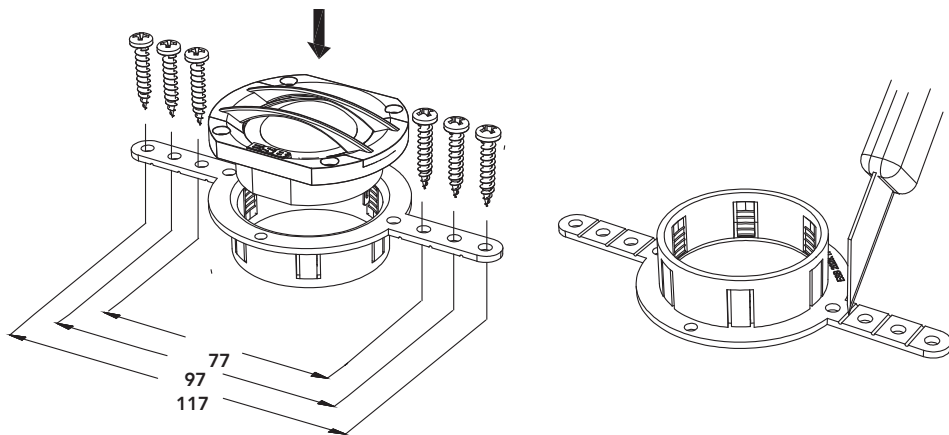

The tweeter can be mounted to a surface via the mounting cup. Choose the angle and position you prefer. Drill holes for cables and screws. After this fasten the cup with two screws. Be safe with the cables, they must be free when the tweeter is inserted into the cup.

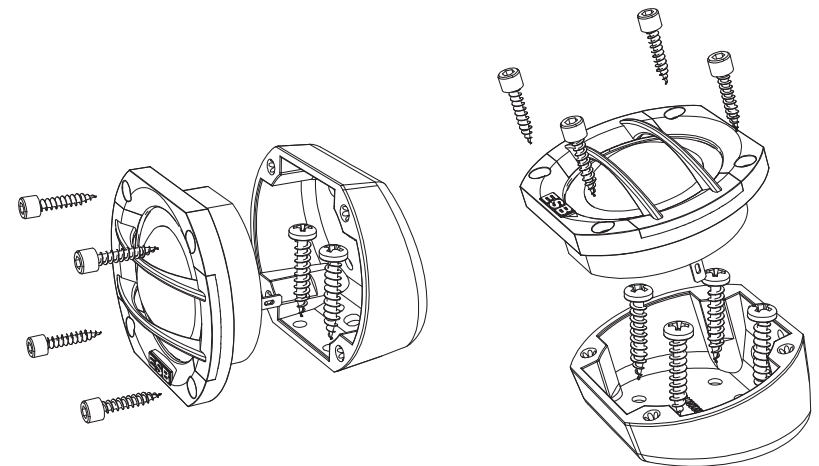

The 2.28 tweeter use a pair of soft and super flexible cable, all are black, but on terminals end there are the polarity identification by red and black insulation tubes.

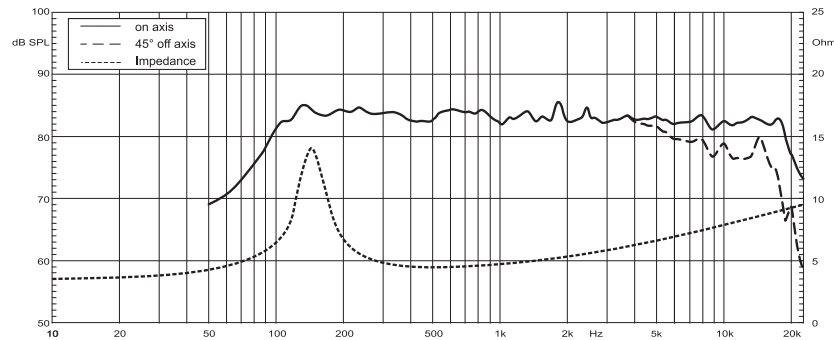
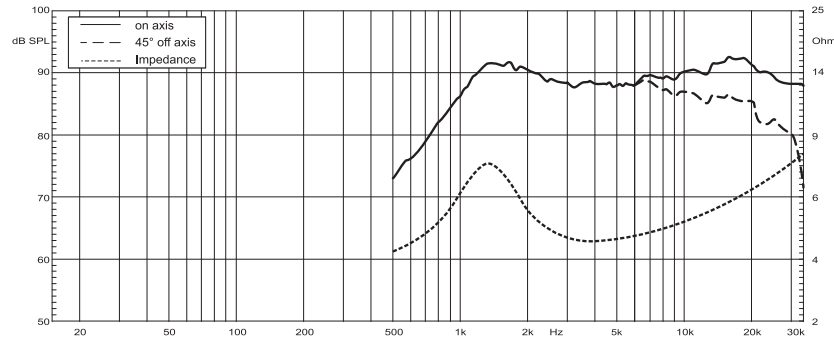

#### MAIN FEATURES

- 25 (Tw)/20 (mid) mm voice coil
- High temperature aluminum/copper voice coil
- Axial forced ventilation
- Neodymium magnet N42 type
- Silk dome tweeter
- Fiber reinforced paper cone midrange
- Super soft roll rubber suspension (mid)
- Fatigue and tear poly cotton spider
- Computer designed ABS frame
- Motor metal parts CNC machined

#### TECHNICAL SPECIFICATIONS

- Power handling: 120 W peak, 60 W continuous
- Frequency response: 100 Hz - 25 KHz +/- 3dB
- Midrange crossover cut-off: From 100Hz 48dB/Oct., from 150Hz 24dB/Oct., from 200Hz 12dB/Oct. from 250Hz 6dB/Oct.
- Tweeter crossover cut-off: From 1.8KHz 48dB/Oct., from 2KHz 18dB/Oct., from 2.2 KHz 12dB/Oct. from 2.5KHz 6dB/Oct.
- Sensitivity: 84 dB SPL 1W/1m
- Dim: 123 x 80 x 44 mm

**NOTE:** Make sure that your mounting location will not cause damage to the components of your vehicle. Check for airbag system location, speaker can't be located over or close it. Never play this component without crossover, especially with high powers, this can damage it. Never play the system with amplifier in clipping or high distortion level. If use a passive crossover, use a dedicated crossover system, don't use a generic passive crossover, these are not designed for this speaker impedance and the indicated cut-off frequency may not be true.

This speaker unit can be installed in A-pillar, kick panel, or in the car's door.

**A-Pillar:** The mounting in the A-pillar has too many variables depending on the shape of the car to be briefly described. The fundamental bases to follow are the distance and the inclination. The position of the UMA must be chosen so that there is the least difference between the units and the front passengers. Normally this position is near the dashboard. The inclination must be chosen so that the UMA is perfectly aligned with the passenger on the opposite side, at the height of his head. We strongly recommend that you do a few listening sessions before permanently fix them.

**Kick panel:** This choice involves the reconstruction of the kick panels with MDF ones. The flat part where the UMA will be fixed must be oriented horizontally towards the center of the car, between the two seats, and vertically at the height of the passengers' heads. The UMA can be installed both with the tweeter facing upwards as well as with it facing downwards (upside down).

**Door:** Select a desired mounting location with an even surface. Tightening a speaker onto an uneven mounting surface can damage it. Mark the center and the outline of the speaker's mounting hole. Use a utility knife to cut any fabric, vinyl or leather from hole locations. After cutting the hole, check to see that the speaker frame fits into its mounting hole cleanly.

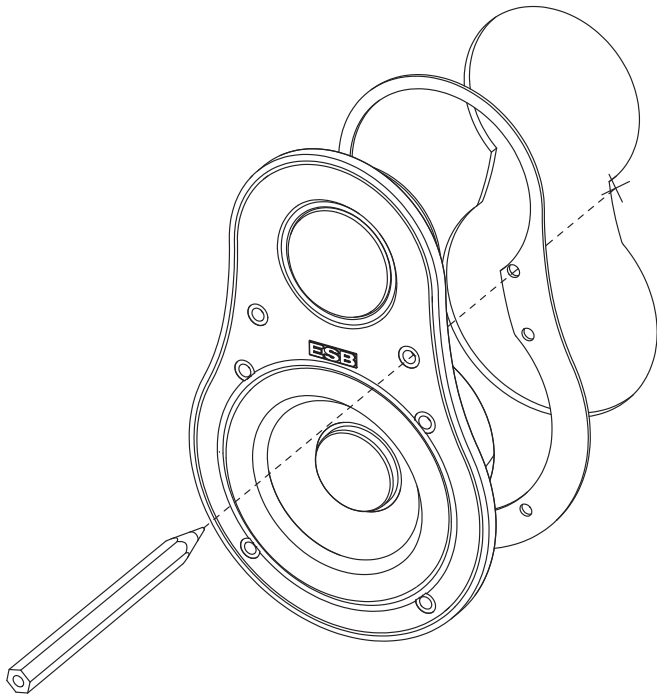

Remove the speaker and drill 2 mm holes at each mark. Connect the speaker wires, observing correct polarity, and be sure wires don't touch any metal part. Make sure the speaker is secured so that air does not leak around the mounting flange. Hand-tighten the screws evenly in a criss-cross pattern to avoid bending the speaker frame or stripping the mounting screw holes. Finally, mount the grille, insert it into the grille gap, pressing around its edge until seated firmly in the gap.

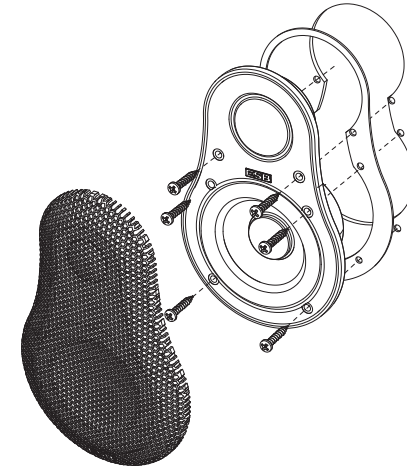

## WIRING YOUR SPEAKER

If you will be using the factory speaker wires, it may be necessary to change the terminations. This may be accomplished by using an adaptor plug or simply by cutting the factory connector off and using the crimp connectors to terminate the speaker wires. The red mark connector is for the positive terminal and black mark connector is for the negative terminal of the speaker. If you choose to run new speaker wires, protect all wiring from sharp edges by carefully routing them, securing them and using grommets and loom where appropriate. If you are running wires into a door, use existing factory wiring boots whenever possible. If you are drilling new holes, file their edges and install rubber grommets into each hole. Wires running into car doors should be covered with a protective, flexible PVC sleeve. Make sure that the wires will clear door hinges and other structures in the door.

This component need a crossover system, you can chose passive or active as well.

The crossover must be high pass type for the tweeter, and band-pass for the midrange midrange. The minimum suggested cutting frequency is 100 Hz (mid) and 1.8 KHz (tw) at 48dB/Oct slope, you can reduce the slope, but remember to reduce the power driving or increase cut-off frequency respectively. These cut-off frequencies are only suggested, right frequency must be calculated and tested directly inside the car, and depend of speaker location, listening angle and car's passenger conformation.

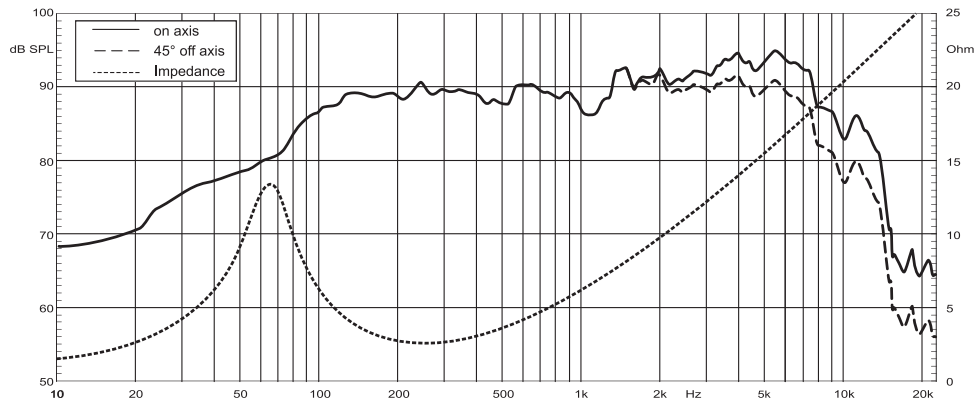

**ESB**  
AUDIO

# 2.165II

## 6.5"/165 mm Mid-Woofer

### Installation Manual

#### MAIN FEATURES

- Copper/aluminum 25 mm voice coil
- FEA motor optimized
- High temperature aluminum former
- Large high grade ferrite magnet
- Axial force coil ventilation
- Fiber reinforced paper cone
- ABS basket with self damping system
- Oversized single wave rubber suspension
- Poly cotton spider
- Balanced symmetrical construction
- Motor metal parts CNC machined

#### TECHNICAL SPECIFICATIONS

- Power handling:  
240 W peak, 120 W continuous
- Frequency response:  
65 Hz - 9 KHz +/- 3dB
- Crossover cut-off:  
From 70Hz 48dB/Oct., from 75Hz 24dB/Oct., from 80Hz 12dB/Oct. from 85Hz 6dB/Oct.
- Sensitivity:  
88.5 dB SPL 1W/1m
- Overall diameter: 165 mm  
Total Height: 74 mm  
Mounting depth: 64 mm  
Mounting hole: 145 mm

**NOTE:** Make sure that your mounting location will not cause damage to the components of your vehicle. Check for airbag system location, speaker can't be located over or close it. Never play this component without crossover, especially with high powers, this can damage it. Never play the system with amplifier in clipping or high distortion level. If use a passive crossover, use a dedicated crossover system, don't use a generic passive crossover, these are not designed for this speaker impedance and the indicated cut-off frequency may not be true.

**DUEMILA**

esbcar.com



**Factory Location:** Your new speakers have been designed to install into most vehicles that accept a 6.5"/165 mm speaker. It is absolutely vital that the speaker frame fits into the mounting hole cleanly. Do not force the frame into a hole that is too small. Do not tighten the speaker onto an uneven mounting surface, this will damage it. The speaker should also fit so that air does not leak around the mounting flange. Use the supplied soft foam gasket to seal any air leak. If air gap is greater than gasket thickness, use an automotive-grade sealant material. Use flat head screws type. Don't use wood screws, these use a conical head and can crack the basket frame.

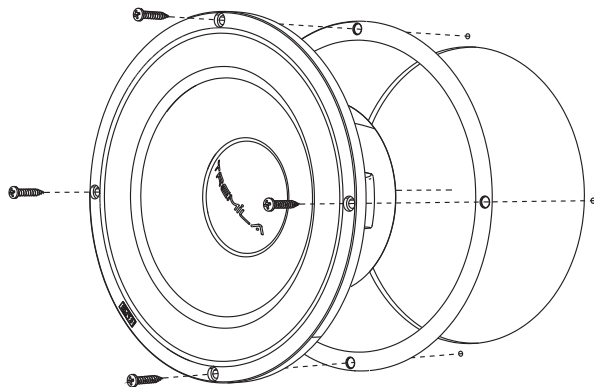

**Custom Location:** Select a desired mounting location with an even surface. Tightening a speaker onto an uneven mounting surface can damage it. Mark the center and the outline of the speaker's mounting hole. Use a utility knife to cut any fabric, vinyl or leather from hole locations. Drill a pilot hole in the center of the proposed speaker mounting hole. Then make the circular cut out for the speaker. After cutting the hole, check to see that the speaker frame fits into its mounting hole cleanly. Once the speaker is in place, use the speaker's mounting holes to mark the panel where the four mounting screws will be positioned.

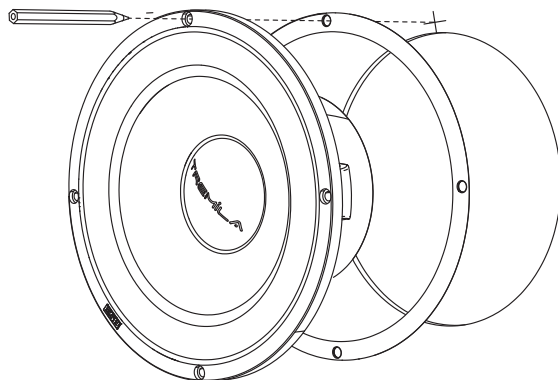

Remove the speaker and drill 2 mm holes at each mark. Connect the speaker wires, observing correct polarity, and be sure wires don't touch any metal part. Make sure the speaker is secured so that air does not leak around the mounting flange. Hand-tighten the screws evenly in a criss-cross pattern to avoid bending the speaker frame or stripping the mounting screw holes.

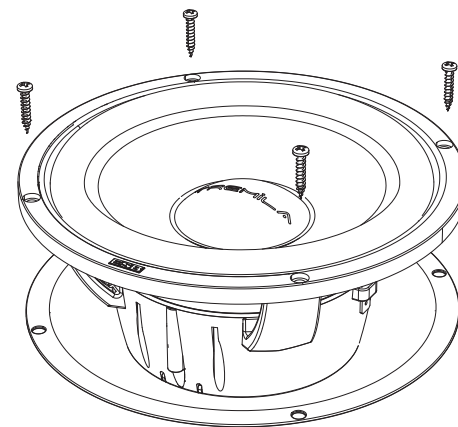

## WIRING YOUR SPEAKER

If you will be using the factory speaker wires, it may be necessary to change the terminations. This may be accomplished by using an adaptor plug or simply by cutting the factory connector off and using the crimp connectors to terminate the speaker wires. The red mark connector is for the positive terminal and black mark connector is for the negative terminal of the speaker. If you choose to run new speaker wires, protect all wiring from sharp edges by carefully routing them, securing them and using grommets and loom where appropriate. If you are running wires into a door, use existing factory wiring boots whenever possible. If you are drilling new holes, file their edges and install rubber grommets into each hole. Wires running into car doors should be covered with a protective, flexible PVC sleeve. Make sure that the wires will clear door hinges and other structures in the door.

This component need a crossover system, you can chose passive or active as well, but we highly suggest active crossover for high-pass type, for low-pass type you can chose passive or active as well. The minimum suggested cutting frequency for high-pass type is 70 Hz at 48 dB/Oct slope, you can reduce the slope, but remember to reduce the power driving or increase cut-off frequency respectively at 75 Hz for 24 dB/Oct, at 80 Hz for 12 dB/Oct and at 85 Hz for 6 dB/Oct. These cut-off frequencies are only suggested, right frequency must be calculated and tested directly inside the car, and depend of speaker location, listening angle and car's passenger compartment conformation.

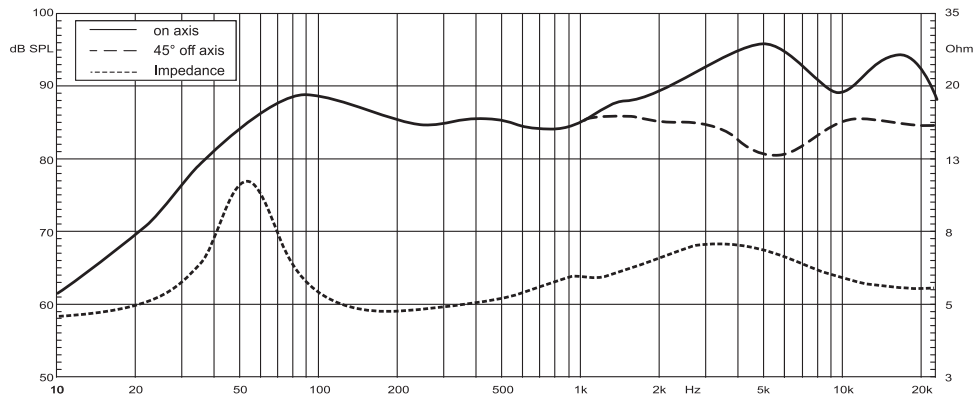

**ESB**  
AUDIO

**2.6C**  
6.5"/165 mm Coaxial

Installation Manual

### MAIN FEATURES

- FEA motor optimized
- 25 mm copper/aluminum voice coil
- High temperature aluminum former
- High-grade ferrite magnet (woofer)
- N35 neodymium magnet (tweeter)
- Axial forced coil ventilation
- Fiber reinforced paper cone (woofer)
- Hi module silk dome (tweeter)
- Oversized single wave rubber suspension (woofer)
- Poly cotton spider (woofer)
- Computer designed ABS frame
- Motor metal part CNC machined

### TECHNICAL SPECIFICATIONS

- Power handling:  
160 W peak, 80 W continuous
- Frequency response:  
65 Hz - 20 KHz +/- 3dB
- Sensitivity:  
88.5 dB SPL 1W/1m
- Overall diameter: 165 mm  
Total Height: 81 mm  
Mounting depth: 64 mm  
Mounting hole: 145 mm

**NOTE:** Make sure that your mounting location will not cause damage to the components of your vehicle. Check for airbag system location, speaker can't be located over or close it. Never play this component without crossover, especially with high powers, this can damage it. Never play the system with amplifier in clipping or high distortion level. If use a passive crossover, use a dedicated crossover system, don't use a generic passive crossover, these are not designed for this speaker impedance and the indicated cut-off frequency may not be true.

**DUEMILA**

esbcar.com

**Factory Location:** Your new speakers have been designed to install into most vehicles that accept a 6.5"/165 mm speaker. It is absolutely vital that the speaker frame fits into the mounting hole cleanly. Do not force the frame into a hole that is too small. Do not tighten the speaker onto an uneven mounting surface, this will damage it. The speaker should also fit so that air does not leak around the mounting flange. Use the supplied soft foam gasket to seal any air leak. If air gap is greater than gasket thickness, use an automotive-grade sealant material. Use flat head screws type. Don't use wood screws, these use a conical head and can crack the basket frame.

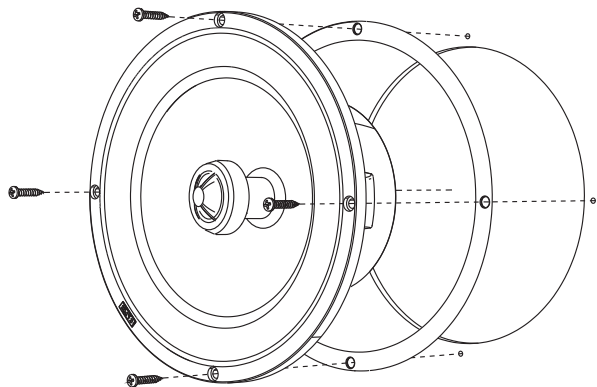

**Custom Location:** Select a desired mounting location with an even surface. Tightening a speaker onto an uneven mounting surface can damage it. Mark the center and the outline of the speaker's mounting hole. Use a utility knife to cut any fabric, vinyl or leather from hole locations. Drill a pilot hole in the center of the proposed speaker mounting hole. Then make the circular cut out for the speaker. After cutting the hole, check to see that the speaker frame fits into its mounting hole cleanly. Once the speaker is in place, use the speaker's mounting holes to mark the panel where the four mounting screws will be positioned.

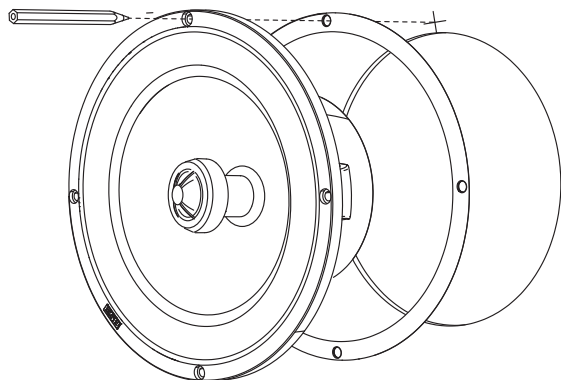

Remove the speaker and drill 2 mm holes at each mark. Connect the speaker wires, observing correct polarity, and be sure wires don't touch any metal part. Make sure the speaker is secured so that air does not leak around the mounting flange. Hand-tighten the screws evenly in a criss-cross pattern to avoid bending the speaker frame or stripping the mounting screw holes.

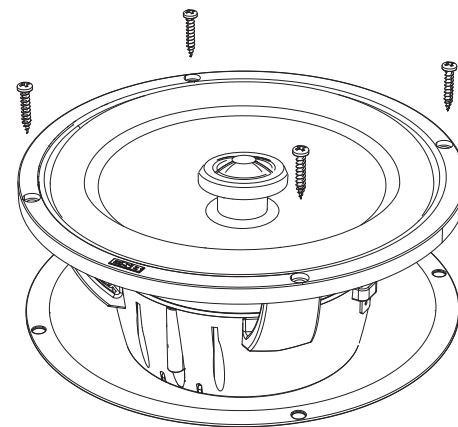

## WIRING YOUR SPEAKER

If you will be using the factory speaker wires, it may be necessary to change the terminations. This may be accomplished by using an adaptor plug or simply by cutting the factory connector off and using the crimp connectors to terminate the speaker wires. The red mark connector is for the positive terminal and black mark connector is for the negative terminal of the speaker. If you choose to run new speaker wires, protect all wiring from sharp edges by carefully routing them, securing them and using grommets and loom where appropriate. If you are running wires into a door, use existing factory wiring boots whenever possible. If you are drilling new holes, file their edges and install rubber grommets into each hole. Wires running into car doors should be covered with a protective, flexible PVC sleeve. Make sure that the wires will clear door hinges and other structures in the door.

This component need a crossover system, you can chose passive or active as well, but we highly suggest active crossover for high-pass type, for low-pass type you can chose passive or active as well. The minimum suggested cutting frequency for high-pass type is 70 Hz at 48 dB/Oct slope, you can reduce the slope, but remember to reduce the power driving or increase cut-off frequency respectively at 75 Hz for 24 dB/Oct, at 80 Hz for 12 dB/Oct and at 85 Hz for 6 dB/Oct. These cut-off frequencies are only suggested, right frequency must be calculated and tested directly inside the car, and depend of speaker location, listening angle and car's passenger compartment conformation.