



3000
Series

Installation Manual

TREMILA



esbcar.com/3000-series
Specifications may change without notice.

esbcar.com

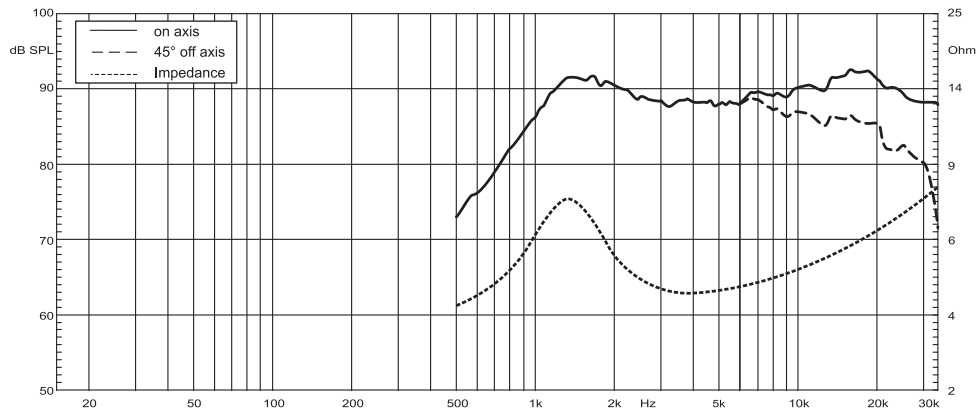

ESB
AUDIO

3.25

1"/25 mm Tweeter

Installation Manual

MAIN FEATURES

- 25 mm voice coil
- Neodymium magnet N42 type
- Light vented aluminum former
- Hi Module Silk dome
- ABS housing with self damping system
- Ferrofluid cooling and damping
- Computer optimized design
- Motor metal parts CNC machined
- Under dome dB Cloth® damping
- Multi angle dash mounting cup
- Flush or free mounting system

TECHNICAL SPECIFICATIONS

- Power handling:
160 W peak, 50 W continuous
- Frequency response:
1.2 - 25 KHz +/- 3dB
- Crossover cut-off:
From 2 KHz to 3.5 KHz 12dB/Oct.
From 2.5 KHz to 3.5 KHz 6dB/Oct.
- Sensitivity:
89 dB SPL 1W/1m
- Size:
Overall diameter: 47 mm
Total Height: 20 mm
Mounting depth: 11 mm
Mounting hole: 40 mm

NOTE: Make sure that your mounting location will not cause damage to the components of your vehicle. Check for airbag system location, speaker can't be located over or close it. Never play this component without crossover, especially with high powers, this can damage it. Never play the system with amplifier in clipping or high distortion level. If use a passive crossover, use a dedicated crossover system, don't use a generic passive crossover, these are not designed for this speaker impedance and the indicated cut-off frequency may not be true.

TREMILA

esbcar.com

The ESB 3.25 tweeter can be installed with different solution, this depend of car type, factory location and tweeter position or listening angle. First solution is to use the back thread hole and with M4x3 screw; use this for fix in an existing panel or use a plastic or steel bracket for fix it. Use flat head screws type. Screw it by hand with limited torque when close. Note: the max screw length must be reduce by washer if you remove the back plate. Never insert any screw over 4 mm inside back thread of tweeter motor, this can crack the magnet and damage the tweeter.

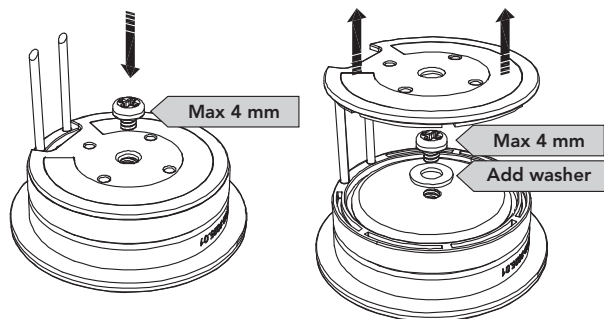

After removed the ring you can place the tweeter in a 43 mm diameter hole in a car panel (max 4 mm thickness). Place the tweeter inside the ring and push from back the fixing ring until listen the click. The outer ring can also be fixed in other ways to the car panel, for example with glue or resin, the tweeter has side hooks with which it is fixed to the ring. For similar mounting and fixing solution use the back screw to fix the metal spring.

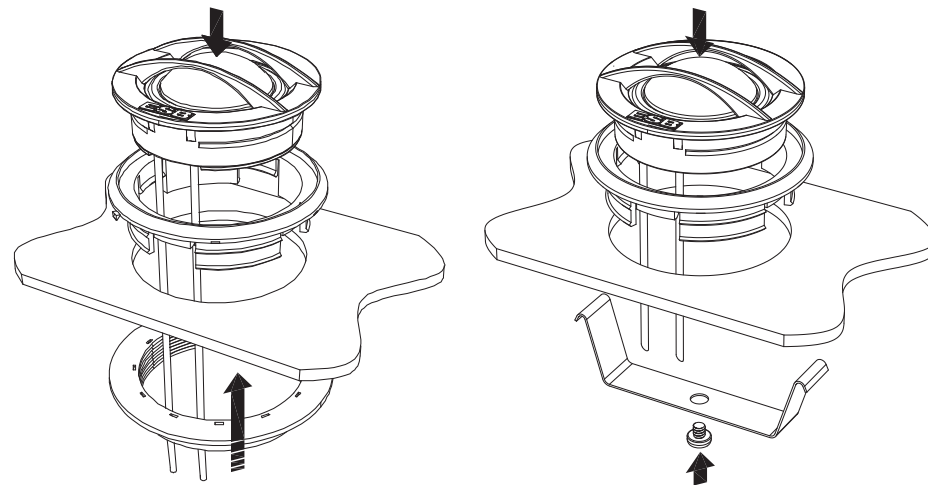

Other mounting system can be with multi holes bracket. Insert tweeter from upper side and the fixing ring from back then push all together to block the three parts. Bracket can be screwed on car factory location by side holes. There are three couple with different lengths (77, 97 and 117 mm). Cut the excess if needed. For flush mounting cut the six "bridges" that join the central ring to the side bracket of the adapter.

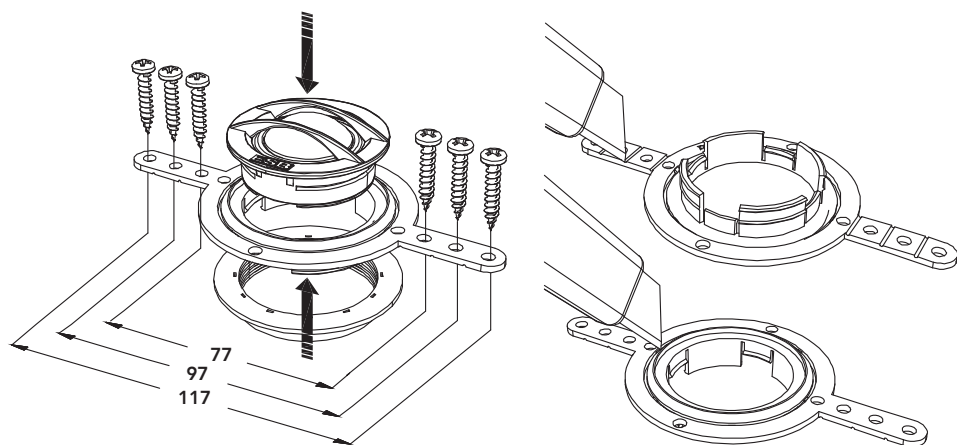

The tweeter can be mounted to a surface via the mounting cup. Choose the angle and position you prefer. Drill holes for cables and screws. After this fasten the cup with two screws. The tweeter is inserted by pressing until the click is heard. Be safe with the cables, they must be free when the tweeter is inserted into the cup.

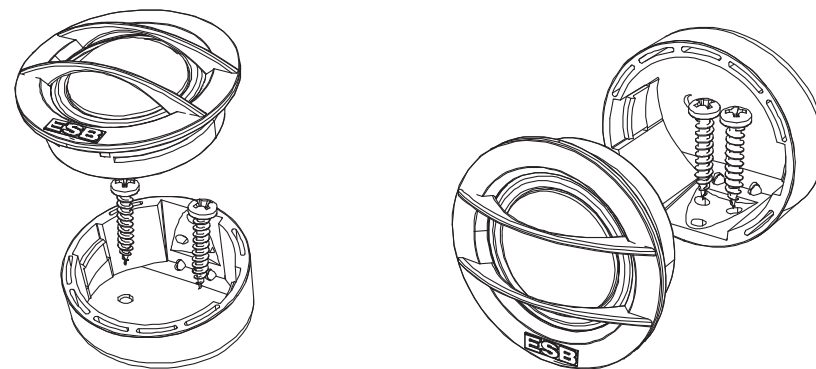

The 3.25 tweeter use a pair of soft and super flexible cable, all are black, but on terminals end there are the polarity identification by red and black insulation tubes.

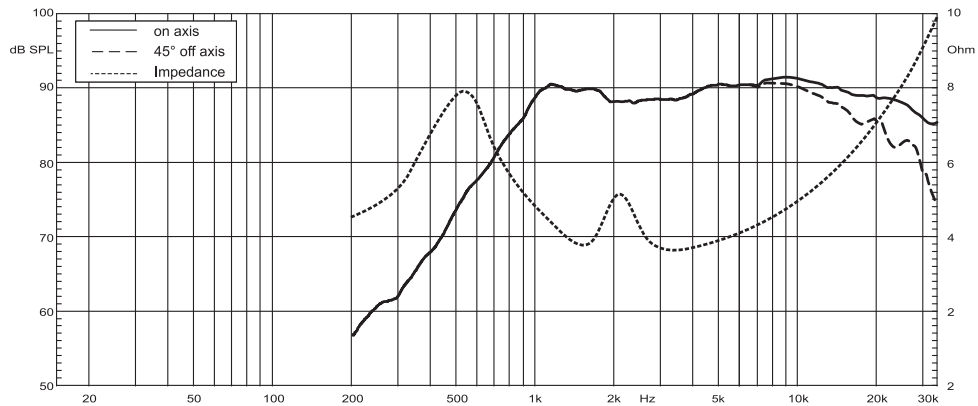

Installation Manual

MAIN FEATURES

- 28 mm voice coil
- Nominal diameter 32.8 mm
- Neodymium magnet N42 type
- Torcon® soft dome
- ABS housing with self damping system
- Ferrofluid cooling and damping
- Computer optimized design
- Motor metal parts CNC machined
- Under dome dB Cloth® damping
- Multi angle dash mounting cup
- Stealth mounting system adaptor

TECHNICAL SPECIFICATIONS

- Power handling:
180 W peak, 90 W continuous
- Frequency response:
900 Hz - 25 KHz +/- 3dB
- Crossover cut-off:
From 2 KHz to 3.5 KHz 12dB/Oct.
From 2.5 KHz to 3.5 KHz 6dB/Oct.
- Sensitivity:
91 dB SPL 1W/1m
- Overall diameter: 58 mm
Total Height: 22 mm
Mounting depth: 11 mm
Mounting hole: 43 mm

NOTE: Make sure that your mounting location will not cause damage to the components of your vehicle. Check for airbag system location, speaker can't be located over or close it. Never play this component without crossover, especially with high powers, this can damage it. Never play the system with amplifier in clipping or high distortion level. If use a passive crossover, use a dedicated crossover system, don't use a generic passive crossover, these are not designed for this speaker impedance and the indicated cut-off frequency may not be true.

TREMILA

The ESB 3.28 tweeter can be installed with different solution, this depend of car type, factory location and tweeter position or listening angle. First solution is to use the back thread hole and with M4x3 screw; use this for fix in an existing panel or use a plastic or steel bracket for fix it. Use flat head screws type. Screw it by hand with limited torque when close. Note: Never insert any screw over 4 mm inside back thread of tweeter motor, this can crack the magnet and damage the tweeter.

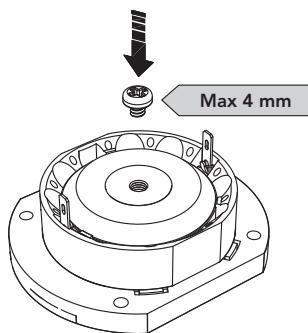

Basic mounting system is to use the four Allen screws and fix the 3.28 by the 4 mounting holes from face-plate. Similar mounting and fixing solution is to use the back screw for fix the metal spring.

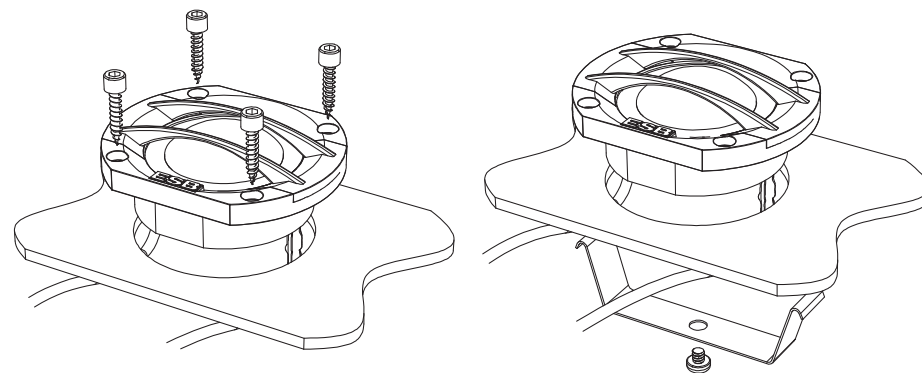

Other mounting system can be with multi holes bracket. Bracket can be screwed on car factory location by side holes. There are three couple with different lengths (77, 97 and 117 mm). Cut the excess if needed. For flush mounting cut the six "bridges" that join the central ring to the side bracket of the adapter. Insert the tweeter from upper side and then push it inside the ring.

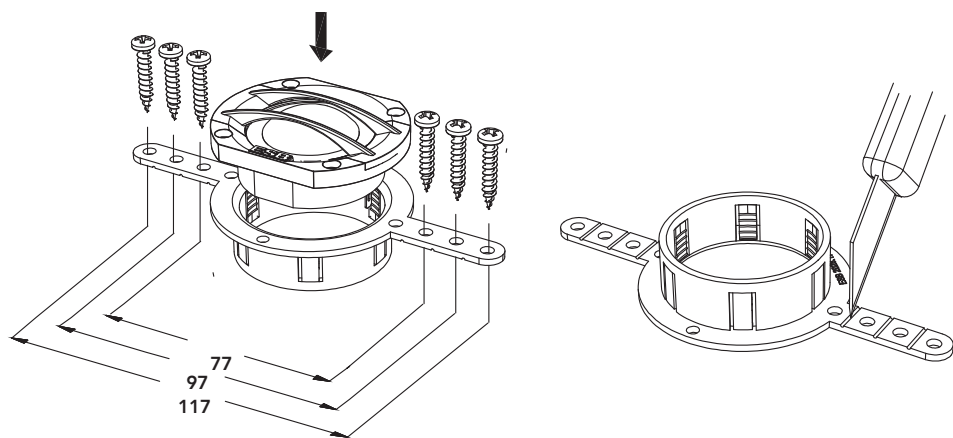

The tweeter can be mounted to a surface via the mounting cup. Choose the angle and position you prefer. Drill holes for cables and screws. After this fasten the cup with two screws. Be safe with the cables, they must be free when the tweeter is inserted into the cup.

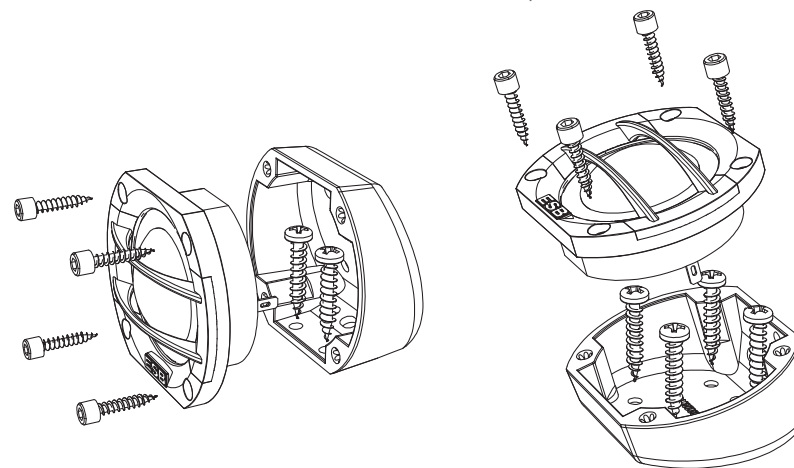

The 3.28 tweeter use a pair of soft and super flexible cable, all are black, but on terminals end there are the polarity identification by red and black insulation tubes.

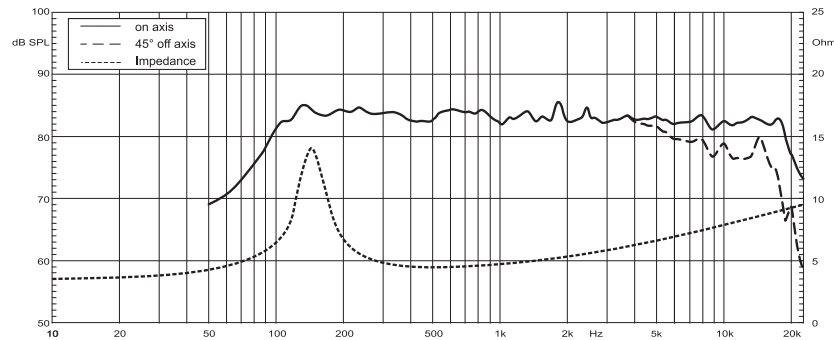
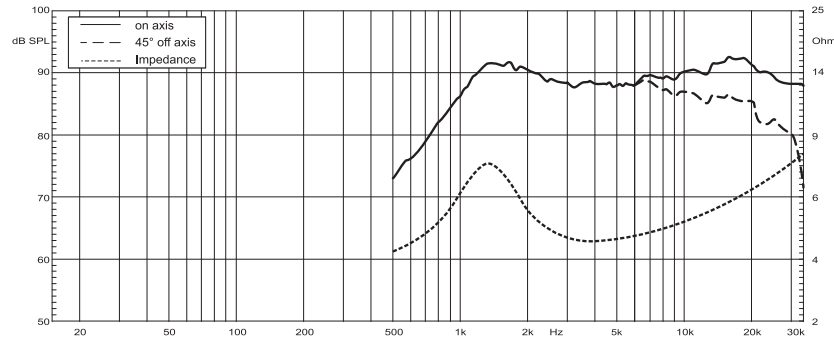

MAIN FEATURES

- 25 (Tw)/20 (mid) mm voice coil
- High temperature aluminum/copper voice coil
- Axial forced ventilation
- Neodymium magnet N42 type
- Silk dome tweeter
- Fiber reinforced paper cone midrange
- Super soft roll rubber suspension (mid)
- Fatigue and tear poly cotton spider
- Computer designed ABS frame
- Motor metal parts CNC machined

TECHNICAL SPECIFICATIONS

- Power handling: 120 W peak, 60 W continuous
- Frequency response: 100 Hz - 25 KHz +/- 3dB
- Midrange crossover cut-off: From 100Hz 48dB/Oct., from 150Hz 24dB/Oct., from 200Hz 12dB/Oct. from 250Hz 6dB/Oct.
- Tweeter crossover cut-off: From 1.8KHz 48dB/Oct., from 2KHz 18dB/Oct., from 2.2 KHz 12dB/Oct. from 2.5KHz 6dB/Oct.
- Sensitivity: 84 dB SPL 1W/1m
- Dim: 123 x 80 x 44 mm

NOTE: Make sure that your mounting location will not cause damage to the components of your vehicle. Check for airbag system location, speaker can't be located over or close it. Never play this component without crossover, especially with high powers, this can damage it. Never play the system with amplifier in clipping or high distortion level. If use a passive crossover, use a dedicated crossover system, don't use a generic passive crossover, these are not designed for this speaker impedance and the indicated cut-off frequency may not be true.



This speaker unit can be installed in A-pillar, kick panel, or in the car's door.

A-Pillar: The mounting in the A-pillar has too many variables depending on the shape of the car to be briefly described. The fundamental bases to follow are the distance and the inclination. The position of the UMA must be chosen so that there is the least difference between the units and the front passengers. Normally this position is near the dashboard. The inclination must be chosen so that the UMA is perfectly aligned with the passenger on the opposite side, at the height of his head. We strongly recommend that you do a few listening sessions before permanently fix them.

Kick panel: This choice involves the reconstruction of the kick panels with MDF ones. The flat part where the UMA will be fixed must be oriented horizontally towards the center of the car, between the two seats, and vertically at the height of the passengers' heads. The UMA can be installed both with the tweeter facing upwards as well as with it facing downwards (upside down).

Door: Select a desired mounting location with an even surface. Tightening a speaker onto an uneven mounting surface can damage it. Mark the center and the outline of the speaker's mounting hole. Use a utility knife to cut any fabric, vinyl or leather from hole locations. After cutting the hole, check to see that the speaker frame fits into its mounting hole cleanly.

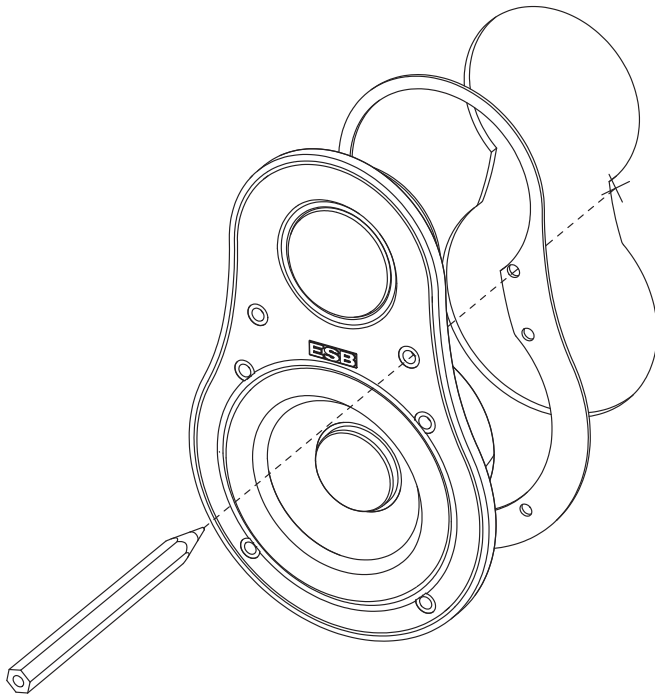

Remove the speaker and drill 2 mm holes at each mark. Connect the speaker wires, observing correct polarity, and be sure wires don't touch any metal part. Make sure the speaker is secured so that air does not leak around the mounting flange. Hand-tighten the screws evenly in a criss-cross pattern to avoid bending the speaker frame or stripping the mounting screw holes. Finally, mount the grille, insert it into the grille gap, pressing around its edge until seated firmly in the gap.

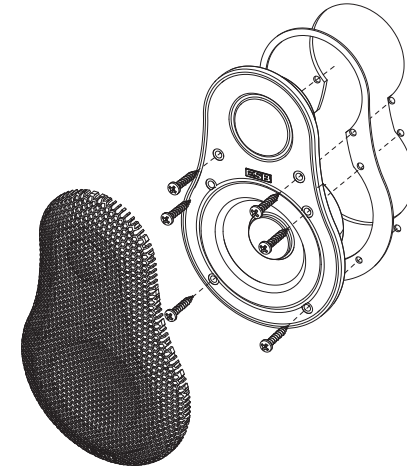

WIRING YOUR SPEAKER

If you will be using the factory speaker wires, it may be necessary to change the terminations. This may be accomplished by using an adaptor plug or simply by cutting the factory connector off and using the crimp connectors to terminate the speaker wires. The red mark connector is for the positive terminal and black mark connector is for the negative terminal of the speaker. If you choose to run new speaker wires, protect all wiring from sharp edges by carefully routing them, securing them and using grommets and loom where appropriate. If you are running wires into a door, use existing factory wiring boots whenever possible. If you are drilling new holes, file their edges and install rubber grommets into each hole. Wires running into car doors should be covered with a protective, flexible PVC sleeve. Make sure that the wires will clear door hinges and other structures in the door.

This component need a crossover system, you can chose passive or active as well.

The crossover must be high pass type for the tweeter, and band-pass for the midrange midrange. The minimum suggested cutting frequency is 100 Hz (mid) and 1.8 KHz (tw) at 48dB/Oct slope, you can reduce the slope, but remember to reduce the power driving or increase cut-off frequency respectively. These cut-off frequencies are only suggested, right frequency must be calculated and tested directly inside the car, and depend of speaker location, listening angle and car's passenger conformation.

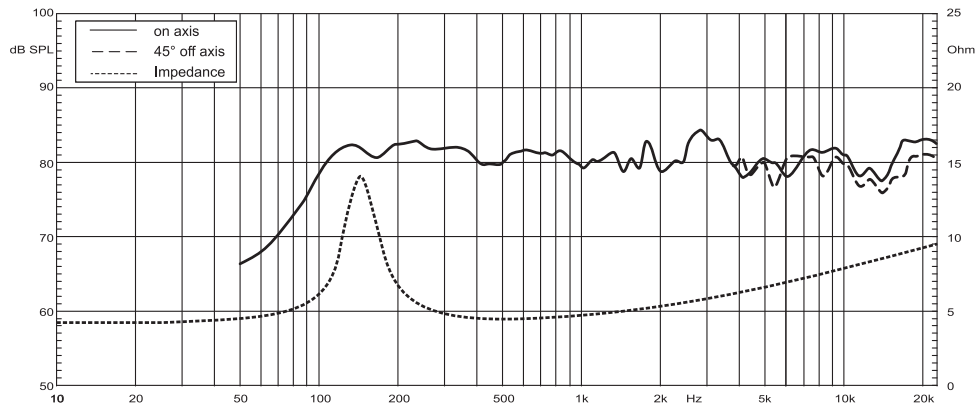

Installation Manual

MAIN FEATURES

- Copper/aluminum 20 mm voice coil
- FEA motor optimized
- Aluminum former
- Neodymium magnet N42 type
- Axial ventilation
- Cellulose fiber exponential cone
- ABS housing with self damping system
- Balanced symmetrical construction
- Conex® progressive spider
- Computer optimized design
- Motor metal parts CNC machined

TECHNICAL SPECIFICATIONS

- Power handling:
120 W peak, 60 W continuous
- Frequency response:
100 Hz - 22 KHz +/- 3dB
- Crossover cut-off:
From 100Hz 48dB/Oct., from 150Hz
24dB/Oct., from 200Hz 12dB/Oct.
from 250Hz 6dB/Oct.
- Sensitivity:
83 dB SPL 1W/1m
- Overall diameter: 76 mm
Total Height: 43 mm
Mounting depth: 36 mm
Mounting hole: 61 mm

NOTE: Make sure that your mounting location will not cause damage to the components of your vehicle. Check for airbag system location, speaker can't be located over or close it. Never play this component without crossover, especially with high powers, this can damage it. Never play the system with amplifier in clipping or high distortion level. If use a passive crossover, use a dedicated crossover system, don't use a generic passive crossover, these are not designed for this speaker impedance and the indicated cut-off frequency may not be true.

TREMILA

Factory Location: Your new speakers have been designed to install into most vehicles that accept a 2.5"/65 mm speaker. It is absolutely vital that the speaker frame fits into the mounting hole cleanly. If factory location use only two holes, drill the other 2 to fix the speaker with all mounting holes. Do not tighten the speaker onto an uneven mounting surface, this will damage it. The speaker should also fit so that air does not leak around the mounting flange. Use the supplied soft foam gasket to seal any air leak. If air gap is greater than gasket thickness, use an automotive-grade sealant material. Use flat head screws type. Don't use wood screws, these use a conical head and can crack the basket frame.

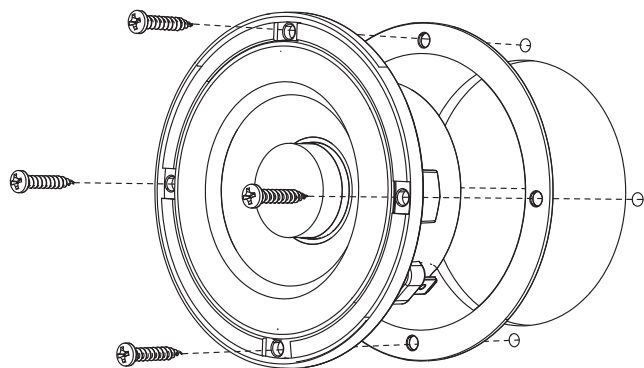

Custom Location: Select a desired mounting location with an even surface. Tightening a speaker onto an uneven mounting surface can damage it. Mark the center and the outline of the speaker's mounting hole. Use a utility knife to cut any fabric, vinyl or leather from hole locations. Drill a pilot hole in the center of the proposed speaker mounting hole. Then make the circular cut out for the speaker. After cutting the hole, check to see that the speaker frame fits into its mounting hole cleanly. Once the speaker is in place, use the speaker's mounting holes to mark the panel where the four mounting screws will be positioned.

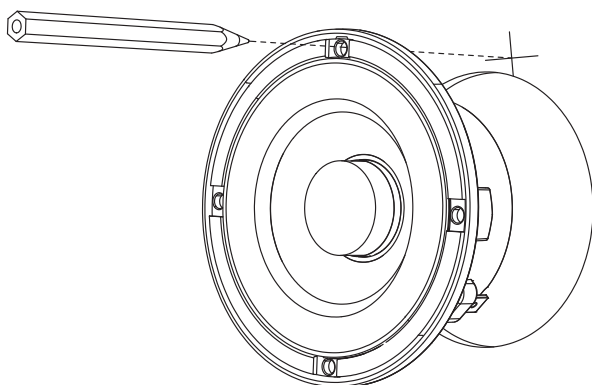

Remove the speaker and drill 2 mm holes at each mark. Connect the speaker wires, observing correct polarity, and be sure wires don't touch any metal part. Make sure the speaker is secured so that air does not leak around the mounting flange. Hand-tighten the screws evenly in a criss-cross pattern to avoid bending the speaker frame or stripping the mounting screw holes. Finally, mount the grille, insert it into the grille gap, pressing around its edge until seated firmly in the gap.

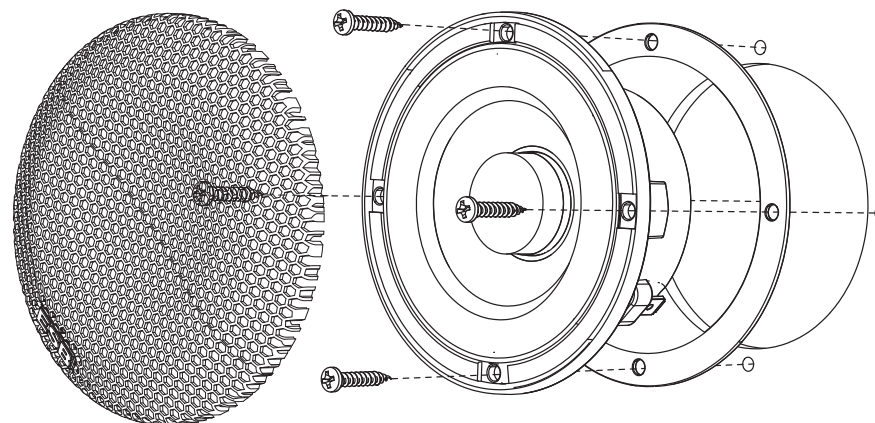

WIRING YOUR SPEAKER

If you will be using the factory speaker wires, it may be necessary to change the terminations. This may be accomplished by using an adaptor plug or simply by cutting the factory connector off and using the crimp connectors to terminate the speaker wires. The red mark connector is for the positive terminal and black mark connector is for the negative terminal of the speaker. If you choose to run new speaker wires, protect all wiring from sharp edges by carefully routing them, securing them and using grommets and loom where appropriate. If you are running wires into a door, use existing factory wiring boots whenever possible. If you are drilling new holes, file their edges and install rubber grommets into each hole. Wires running into car doors should be covered with a protective, flexible PVC sleeve. Make sure that the wires will clear door hinges and other structures in the door.

This component need a crossover system, you can chose passive or active as well.

The crossover must be high pass type if component is used as widerange, or band-pass if component is used as midrange. The minimum suggested cutting frequency is 100 Hz at 48dB/Oct slope, you can reduce the slope, but remember to reduce the power driving or increase cut-off frequency respectively at 150 Hz for 24 dB/Oct, at 200 Hz for 12 dB/Oct and at 250 Hz for 6 dB/Oct. These cut-off frequencies are only suggested, right frequency must be calculated and tested directly inside the car, and depend of speaker location, listening angle and car's passenger conformation.

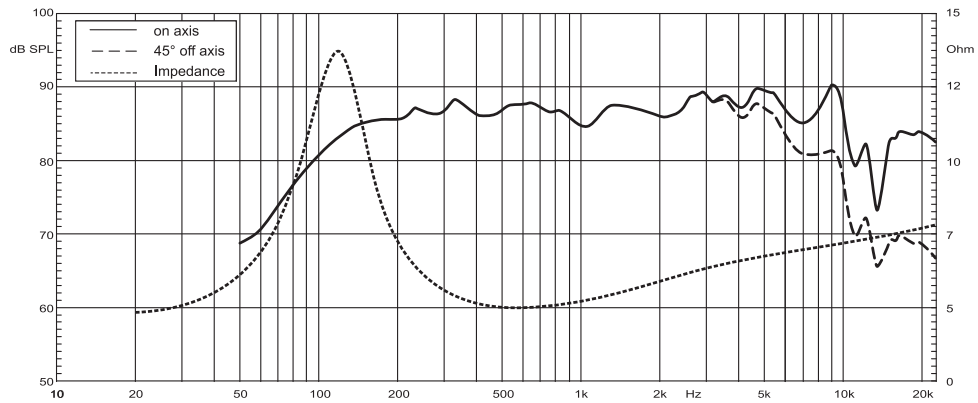

ESB
AUDIO

3.90

3.5"/90 mm Midrange

Installation Manual

MAIN FEATURES

- Copper/aluminum 20 mm voice coil
- FEA motor optimized
- High temperature aluminum former
- Large high grade ferrite magnet
- Axial force coil ventilation
- Fiber reinforced paper cone
- Computer designed ABS frame
- Twin symmetrical wave rubber suspension
- Poly cotton spider
- Lead wire, balanced connection
- Motor metal parts CNC machined

TECHNICAL SPECIFICATIONS

- Power handling:
120 W peak, 60 W continuous
- Frequency response:
150 Hz - 7 KHz +/- 3dB
- Crossover cut-off:
From 150Hz 48dB/Oct. or 24dB/Oct.
From 200Hz 12dB/Oct.
From 250Hz 6dB/Oct.
- Sensitivity:
88.5 dB SPL 1W/1m
- Overall diameter: 100 mm
Total Height: 42 mm
Mounting depth: 38 mm
Mounting hole: 77 mm

NOTE: Make sure that your mounting location will not cause damage to the components of your vehicle. Check for airbag system location, speaker can't be located over or close it. Never play this component without crossover, especially with high powers, this can damage it. Never play the system with amplifier in clipping or high distortion level. If use a passive crossover, use a dedicated crossover system, don't use a generic passive crossover, these are not designed for this speaker impedance and the indicated cut-off frequency may not be true.

TREMILA

esbcar.com

Factory Location: Your new speakers have been designed to install into most vehicles that accept a 3.5"/90 mm speaker. It is absolutely vital that the speaker frame fits into the mounting hole cleanly. Do not force the frame into a hole that is too small. Do not tighten the speaker onto an uneven mounting surface, this will damage it. The speaker should also fit so that air does not leak around the mounting flange. Use the supplied soft foam gasket to seal any air leak. If air gap is greater than gasket thickness, use an automotive-grade sealant material. Use flat head screws type. Don't use wood screws, these use a conical head and can crack the basket frame.

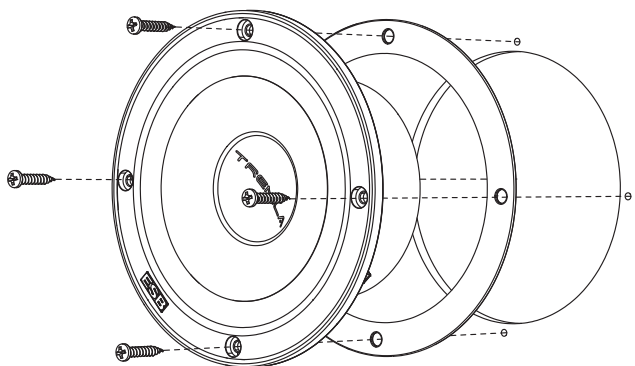

Custom Location: Select a desired mounting location with an even surface. Tightening a speaker onto an uneven mounting surface can damage it. Mark the center and the outline of the speaker's mounting hole. Use a utility knife to cut any fabric, vinyl or leather from hole locations. Drill a pilot hole in the center of the proposed speaker mounting hole. Then make the circular cut out for the speaker. After cutting the hole, check to see that the speaker frame fits into its mounting hole cleanly. Once the speaker is in place, use the speaker's mounting holes to mark the panel where the four mounting screws will be positioned.

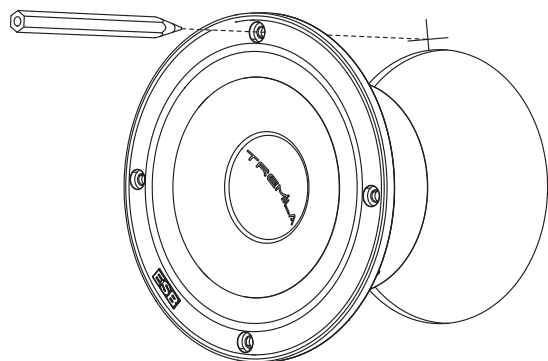

Remove the speaker and drill 2 mm holes at each mark. Connect the speaker wires, observing correct polarity, and be sure wires don't touch any metal part. Make sure the speaker is secured so that air does not leak around the mounting flange. Hand-tighten the screws evenly in a criss-cross pattern to avoid bending the speaker frame or stripping the mounting screw holes. Finally, mount the grille, insert it into the grille gap, pressing around its edge until seated firmly in the gap.

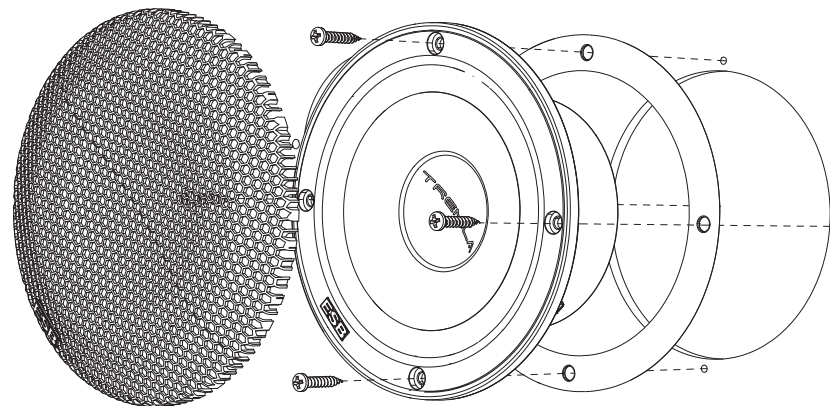

WIRING YOUR SPEAKER

If you will be using the factory speaker wires, it may be necessary to change the terminations. This may be accomplished by using an adaptor plug or simply by cutting the factory connector off and using the crimp connectors to terminate the speaker wires. The red mark connector is for the positive terminal and black mark connector is for the negative terminal of the speaker. If you choose to run new speaker wires, protect all wiring from sharp edges by carefully routing them, securing them and using grommets and loom where appropriate. If you are running wires into a door, use existing factory wiring boots whenever possible. If you are drilling new holes, file their edges and install rubber grommets into each hole. Wires running into car doors should be covered with a protective, flexible PVC sleeve. Make sure that the wires will clear door hinges and other structures in the door.

This component need a crossover system, you can chose passive or active as well. The crossover must be band-pass type. The minimum suggested cutting frequency is 150 Hz at 48dB/Oct or 24 dB/Oct slope, you can reduce the slope, but remember to reduce the power driving or increase cut-off frequency respectively at 200 Hz for 12 dB/Oct and 6 dB/Oct. These cut-off frequencies are only suggested, right frequency must be calculated and tested directly inside the car, and depend of speaker location, listening angle and car's passenger compartment conformation.



3.165

6.5"/165 mm Mid-Woofer

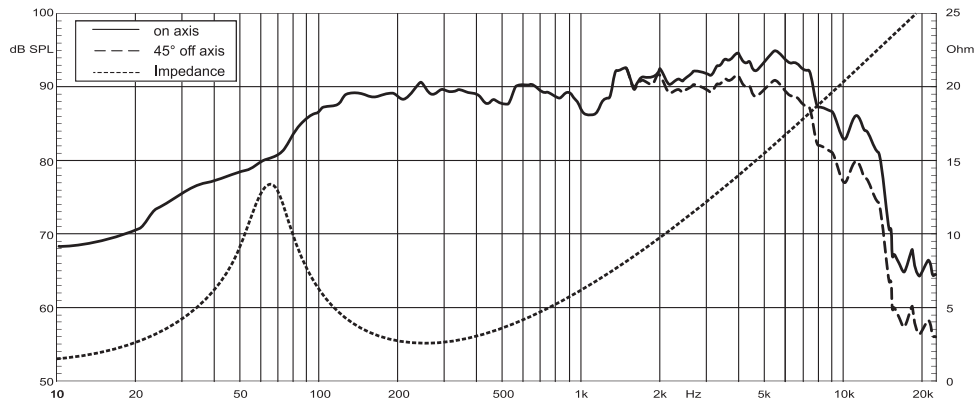

Installation Manual

MAIN FEATURES

- Copper/aluminum 25 mm voice coil
- FEA motor optimized
- High temperature aluminum former
- Large high grade ferrite magnet
- Axial force coil ventilation
- Fiber reinforced paper cone
- ABS basket with self damping system
- Oversized single wave rubber suspension
- Poly cotton spider
- Balanced symmetrical construction
- Motor metal parts CNC machined

TECHNICAL SPECIFICATIONS

- Power handling:
240 W peak, 120 W continuous
- Frequency response:
65 Hz - 9 KHz +/- 3dB
- Crossover cut-off:
From 70Hz 48dB/Oct., from 75Hz
24dB/Oct., from 80Hz 12dB/Oct.
from 85Hz 6dB/Oct.
- Sensitivity:
88.5 dB SPL 1W/1m
- Overall diameter: 165 mm
Total Height: 74 mm
Mounting depth: 64 mm
Mounting hole: 145 mm

NOTE: Make sure that your mounting location will not cause damage to the components of your vehicle. Check for airbag system location, speaker can't be located over or close it. Never play this component without crossover, especially with high powers, this can damage it. Never play the system with amplifier in clipping or high distortion level. If use a passive crossover, use a dedicated crossover system, don't use a generic passive crossover, these are not designed for this speaker impedance and the indicated cut-off frequency may not be true.

TREMILA

esbcar.com

Factory Location: Your new speakers have been designed to install into most vehicles that accept a 6.5"/165 mm speaker. It is absolutely vital that the speaker frame fits into the mounting hole cleanly. Do not force the frame into a hole that is too small. Do not tighten the speaker onto an uneven mounting surface, this will damage it. The speaker should also fit so that air does not leak around the mounting flange. Use the supplied soft foam gasket to seal any air leak. If air gap is greater than gasket thickness, use an automotive-grade sealant material. Use flat head screws type. Don't use wood screws, these use a conical head and can crack the basket frame.

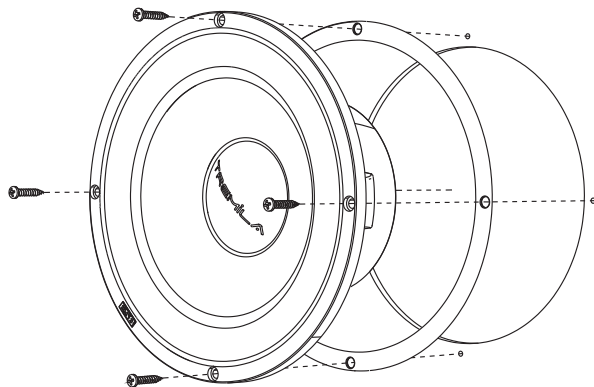

Custom Location: Select a desired mounting location with an even surface. Tightening a speaker onto an uneven mounting surface can damage it. Mark the center and the outline of the speaker's mounting hole. Use a utility knife to cut any fabric, vinyl or leather from hole locations. Drill a pilot hole in the center of the proposed speaker mounting hole. Then make the circular cut out for the speaker. After cutting the hole, check to see that the speaker frame fits into its mounting hole cleanly. Once the speaker is in place, use the speaker's mounting holes to mark the panel where the four mounting screws will be positioned.

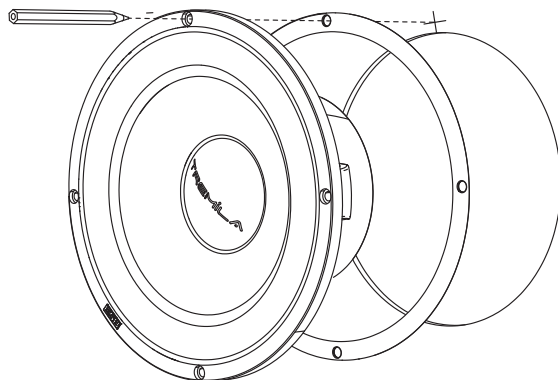

Remove the speaker and drill 2 mm holes at each mark. Connect the speaker wires, observing correct polarity, and be sure wires don't touch any metal part. Make sure the speaker is secured so that air does not leak around the mounting flange. Hand-tighten the screws evenly in a criss-cross pattern to avoid bending the speaker frame or stripping the mounting screw holes.

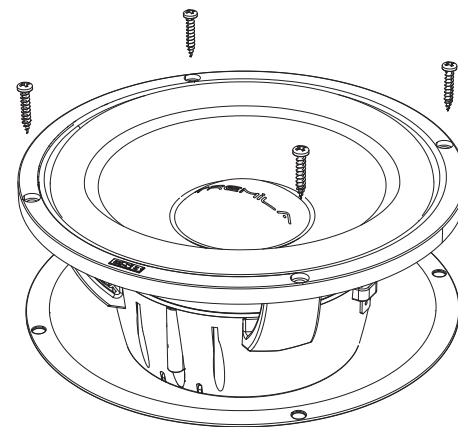

WIRING YOUR SPEAKER

If you will be using the factory speaker wires, it may be necessary to change the terminations. This may be accomplished by using an adaptor plug or simply by cutting the factory connector off and using the crimp connectors to terminate the speaker wires. The red mark connector is for the positive terminal and black mark connector is for the negative terminal of the speaker. If you choose to run new speaker wires, protect all wiring from sharp edges by carefully routing them, securing them and using grommets and loom where appropriate. If you are running wires into a door, use existing factory wiring boots whenever possible. If you are drilling new holes, file their edges and install rubber grommets into each hole. Wires running into car doors should be covered with a protective, flexible PVC sleeve. Make sure that the wires will clear door hinges and other structures in the door.

This component need a crossover system, you can chose passive or active as well, but we highly suggest active crossover for high-pass type, for low-pass type you can chose passive or active as well. The minimum suggested cutting frequency for high-pass type is 70 Hz at 48 dB/Oct slope, you can reduce the slope, but remember to reduce the power driving or increase cut-off frequency respectively at 75 Hz for 24 dB/Oct, at 80 Hz for 12 dB/Oct and at 85 Hz for 6 dB/Oct. These cut-off frequencies are only suggested, right frequency must be calculated and tested directly inside the car, and depend of speaker location, listening angle and car's passenger compartment conformation.

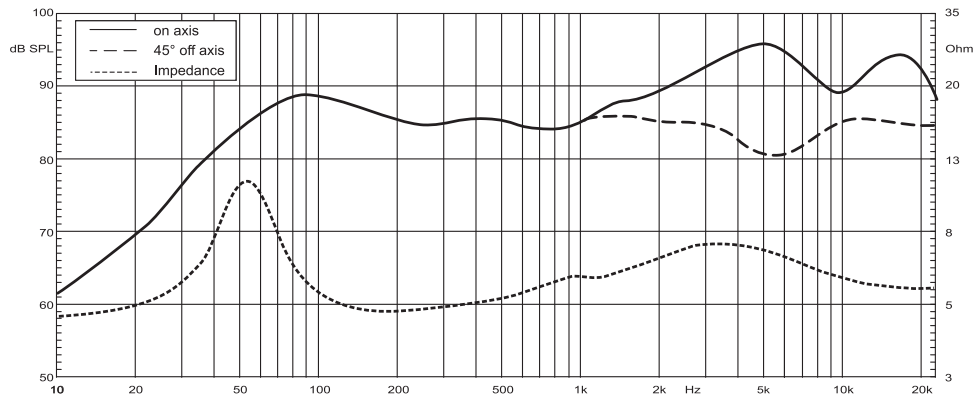

ESB
AUDIO

3.6C

6.5"/165 mm Coaxial

Installation Manual

MAIN FEATURES

- FEA motor optimized
- 25 mm copper/aluminum voice coil
- High temperature aluminum former
- High-grade ferrite magnet (woofer)
- N35 neodymium magnet (tweeter)
- Axial forced coil ventilation
- Fiber reinforced paper cone (woofer)
- Hi module silk dome (tweeter)
- Oversized single wave rubber suspension (woofer)
- Poly cotton spider (woofer)
- Computer designed ABS frame
- Motor metal part CNC machined

TECHNICAL SPECIFICATIONS

- Power handling:
160 W peak, 80 W continuous
- Frequency response:
65 Hz - 20 KHz +/- 3dB
- Sensitivity:
88.5 dB SPL 1W/1m
- Overall diameter: 165 mm
Total Height: 81 mm
Mounting depth: 64 mm
Mounting hole: 145 mm

NOTE: Make sure that your mounting location will not cause damage to the components of your vehicle. Check for airbag system location, speaker can't be located over or close it. Never play this component without crossover, especially with high powers, this can damage it. Never play the system with amplifier in clipping or high distortion level. If use a passive crossover, use a dedicated crossover system, don't use a generic passive crossover, these are not designed for this speaker impedance and the indicated cut-off frequency may not be true.

TREMILA

esbcar.com

Factory Location: Your new speakers have been designed to install into most vehicles that accept a 6.5"/165 mm speaker. It is absolutely vital that the speaker frame fits into the mounting hole cleanly. Do not force the frame into a hole that is too small. Do not tighten the speaker onto an uneven mounting surface, this will damage it. The speaker should also fit so that air does not leak around the mounting flange. Use the supplied soft foam gasket to seal any air leak. If air gap is greater than gasket thickness, use an automotive-grade sealant material. Use flat head screws type. Don't use wood screws, these use a conical head and can crack the basket frame.

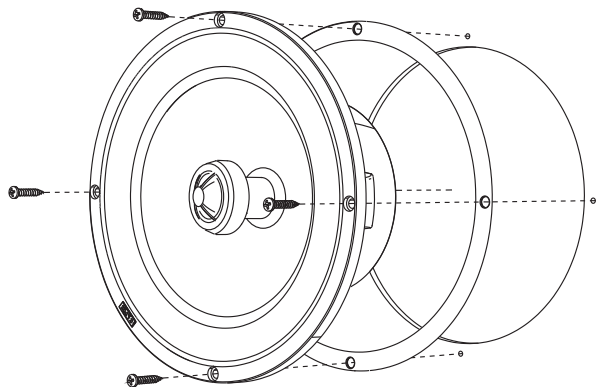

Custom Location: Select a desired mounting location with an even surface. Tightening a speaker onto an uneven mounting surface can damage it. Mark the center and the outline of the speaker's mounting hole. Use a utility knife to cut any fabric, vinyl or leather from hole locations. Drill a pilot hole in the center of the proposed speaker mounting hole. Then make the circular cut out for the speaker. After cutting the hole, check to see that the speaker frame fits into its mounting hole cleanly. Once the speaker is in place, use the speaker's mounting holes to mark the panel where the four mounting screws will be positioned.

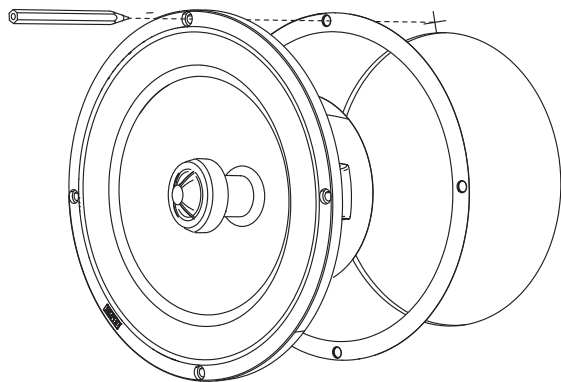

Remove the speaker and drill 2 mm holes at each mark. Connect the speaker wires, observing correct polarity, and be sure wires don't touch any metal part. Make sure the speaker is secured so that air does not leak around the mounting flange. Hand-tighten the screws evenly in a criss-cross pattern to avoid bending the speaker frame or stripping the mounting screw holes.

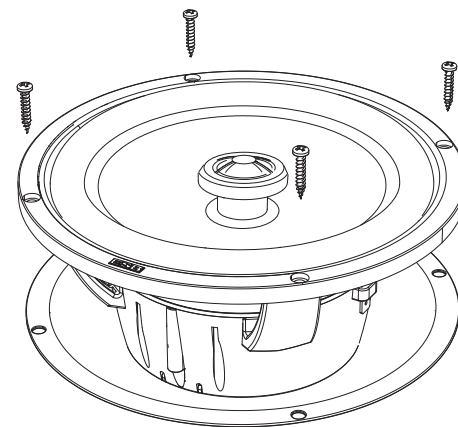

WIRING YOUR SPEAKER

If you will be using the factory speaker wires, it may be necessary to change the terminations. This may be accomplished by using an adaptor plug or simply by cutting the factory connector off and using the crimp connectors to terminate the speaker wires. The red mark connector is for the positive terminal and black mark connector is for the negative terminal of the speaker. If you choose to run new speaker wires, protect all wiring from sharp edges by carefully routing them, securing them and using grommets and loom where appropriate. If you are running wires into a door, use existing factory wiring boots whenever possible. If you are drilling new holes, file their edges and install rubber grommets into each hole. Wires running into car doors should be covered with a protective, flexible PVC sleeve. Make sure that the wires will clear door hinges and other structures in the door.

This component need a crossover system, you can chose passive or active as well, but we highly suggest active crossover for high-pass type, for low-pass type you can chose passive or active as well. The minimum suggested cutting frequency for high-pass type is 70 Hz at 48 dB/Oct slope, you can reduce the slope, but remember to reduce the power driving or increase cut-off frequency respectively at 75 Hz for 24 dB/Oct, at 80 Hz for 12 dB/Oct and at 85 Hz for 6 dB/Oct. These cut-off frequencies are only suggested, right frequency must be calculated and tested directly inside the car, and depend of speaker location, listening angle and car's passenger compartment conformation.

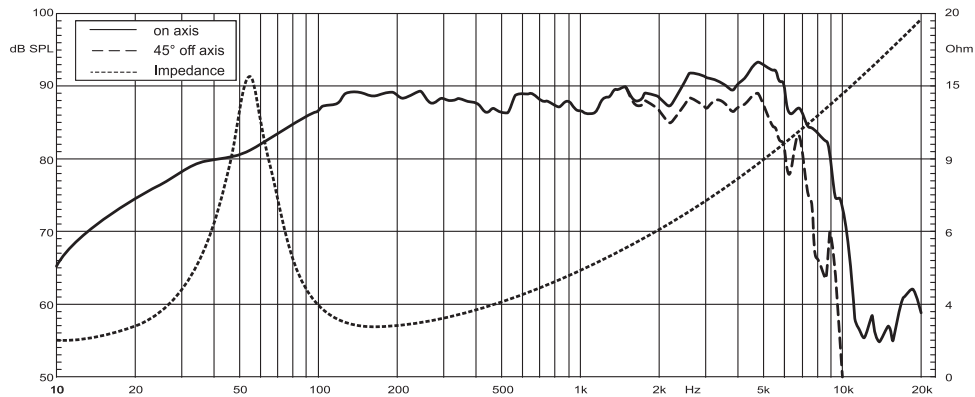

ESB
AUDIO

3.69

6 x 9" / 150 x 230 mm
Woofer

Installation Manual

MAIN FEATURES

- Copper/aluminum 25 mm voice coil
- FEA motor optimized
- High temperature aluminum former
- Large high grade ferrite magnet
- Axial force coil ventilation
- Fiber reinforced paper cone
- ABS basket with self damping system
- Oversized single wave rubber suspension
- Poly cotton spider
- Balanced symmetrical construction
- Motor metal parts CNC machined

TECHNICAL SPECIFICATIONS

- Power handling:
240 W peak, 120 W continuous
- Frequency response:
55 Hz - 9 KHz +/- 3dB
- Crossover cut-off:
From 65Hz 48dB/Oct., from 70Hz
24dB/Oct., from 75Hz 12dB/Oct.
from 80Hz 6dB/Oct.
- Sensitivity:
88.5 dB SPL 1W/1m
- Overall diameter: 168 x 235 mm
Total Height: 82 mm
Mounting depth: 72 mm
Mounting hole: 148 x 215 mm

NOTE: Make sure that your mounting location will not cause damage to the components of your vehicle. Check for airbag system location, speaker can't be located over or close it. Never play this component without crossover, especially with high powers, this can damage it. Never play the system with amplifier in clipping or high distortion level. If use a passive crossover, use a dedicated crossover system, don't use a generic passive crossover, these are not designed for this speaker impedance and the indicated cut-off frequency may not be true.

TREMILA

esbcar.com

Factory Location: Your new speakers have been designed to install into most vehicles that accept a 6x9"/150x230 mm speaker. It is absolutely vital that the speaker frame fits into the mounting hole cleanly. Do not force the frame into a hole that is too small. Do not tighten the speaker onto an uneven mounting surface, this will damage it. The speaker should also fit so that air does not leak around the mounting flange. Use the supplied soft foam gasket to seal any air leak. If air gap is greater than gasket thickness, use an automotive-grade sealant material. Use flat head screws type. Don't use wood screws, these use a conical head and can crack the basket frame.

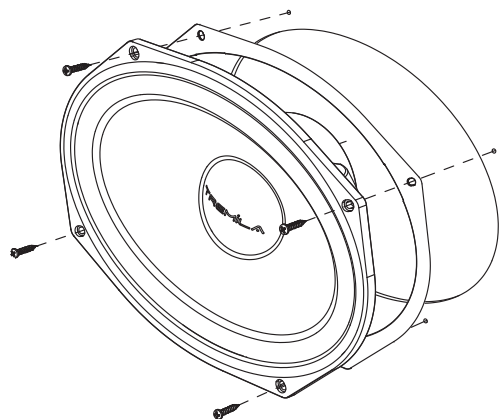

Custom Location: Select a desired mounting location with an even surface. Tightening a speaker onto an uneven mounting surface can damage it. Mark the center and the outline of the speaker's mounting hole. Use a utility knife to cut any fabric, vinyl or leather from hole locations. Drill a pilot hole in the center of the proposed speaker mounting hole. Then make the circular cut out for the speaker. After cutting the hole, check to see that the speaker frame fits into its mounting hole cleanly. Once the speaker is in place, use the speaker's mounting holes to mark the panel where the four mounting screws will be positioned.

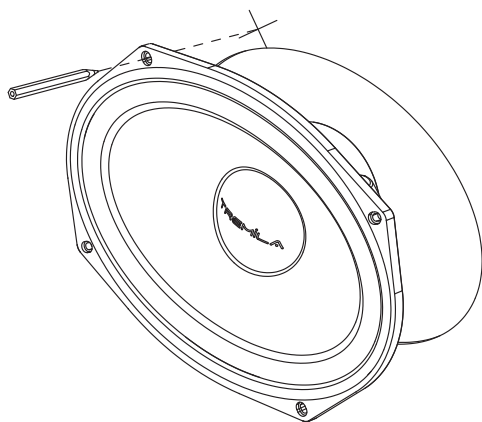

Remove the speaker and drill 2 mm holes at each mark. Connect the speaker wires, observing correct polarity, and be sure wires don't touch any metal part. Make sure the speaker is secured so that air does not leak around the mounting flange. Hand-tighten the screws evenly in a criss-cross pattern to avoid bending the speaker frame or stripping the mounting screw holes.

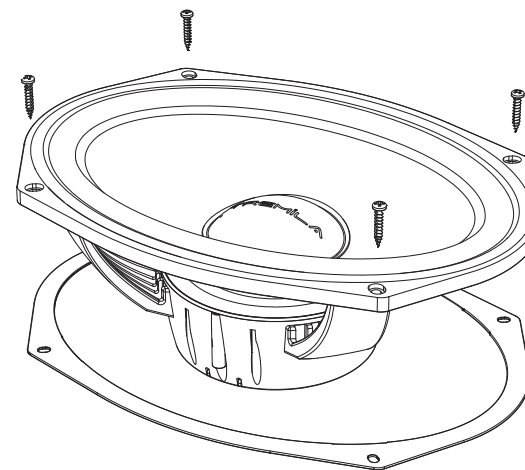

WIRING YOUR SPEAKER

If you will be using the factory speaker wires, it may be necessary to change the terminations. This may be accomplished by using an adaptor plug or simply by cutting the factory connector off and using the crimp connectors to terminate the speaker wires. The red mark connector is for the positive terminal and black mark connector is for the negative terminal of the speaker. If you choose to run new speaker wires, protect all wiring from sharp edges by carefully routing them, securing them and using grommets and loom where appropriate. If you are running wires into a door, use existing factory wiring boots whenever possible. If you are drilling new holes, file their edges and install rubber grommets into each hole. Wires running into car doors should be covered with a protective, flexible PVC sleeve. Make sure that the wires will clear door hinges and other structures in the door.

This component need a crossover system, you can chose passive or active as well, but we highly suggest active crossover for high-pass type, for low-pass type you can chose passive or active as well. The minimum suggested cutting frequency for high-pass type is 65 Hz at 48dB/Oct slope, you can reduce the slope, but remember to reduce the power driving or increase cut-off frequency respectively at 70 Hz for 24 dB/Oct, at 75 Hz for 12 dB/Oct and at 80 Hz for 6 dB/Oct. These cut-off frequencies are only suggested, right frequency must be calculated and tested directly inside the car, and depend of speaker location, listening angle and car's passenger compartment conformation.

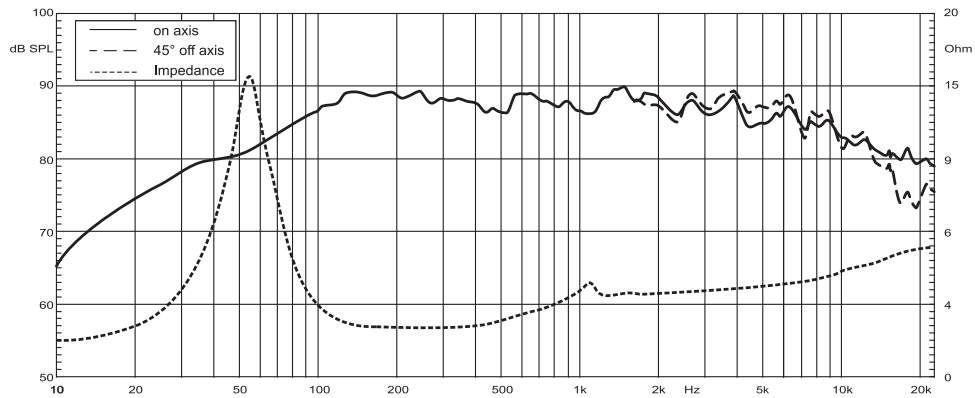

ESB
AUDIO

3.69C

6 x 9" / 150 x 230 mm
Convertible Speaker

Installation Manual

MAIN FEATURES

- FEA motor optimized
- 25 mm copper/aluminum voice coil
- High temperature aluminum former
- High-grade ferrite magnet (woofer)
- N42 neodymium magnet (tweeter)
- Axial forced coil ventilation
- Fiber reinforced paper cone (woofer)
- Hi module silk dome (tweeter)
- Oversized single wave rubber suspension (woofer)
- Poly cotton spider (woofer)
- Computer designed ABS frame
- Motor metal part CNC machined

TECHNICAL SPECIFICATIONS

- Power handling:
240 W peak, 120 W continuous
- Frequency response:
55 Hz - 25 KHz +/- 3dB
- Sensitivity:
88.5 dB SPL 1W/1m
- Overall diameter: 168 x 235 mm
Total Height: 83 mm
Mounting depth: 72 mm
Mounting hole: 148 x 215 mm

NOTE: Make sure that your mounting location will not cause damage to the components of your vehicle. Check for airbag system location, speaker can't be located over or close it. Never play this component without crossover, especially with high powers, this can damage it. Never play the system with amplifier in clipping or high distortion level. If use a passive crossover, use a dedicated crossover system, don't use a generic passive crossover, these are not designed for this speaker impedance and the indicated cut-off frequency may not be true.

TREMILA

esbcar.com

Crossover Network: The crossover terminals area are separated as red zone and black zone: all connectors on red zone are positive (+) and all connectors on black zone are negative (-). Wires from the amplifier outputs must be connected on terminal labeled IN+ and IN-. The positive and negative outputs of the woofer connections are labeled W+ and W- on the crossover and should be connected to corresponding terminals on woofer. The tweeter connections are labeled as TW+ and TW-. Wires out of tweeter use black and red insulator tubes, red (positive) must be connected to TW+. The crossover can be fixed directly to the woofer frame by a slide joint and locked by a screw, or it can be used separately and fixed in another place inside the car.

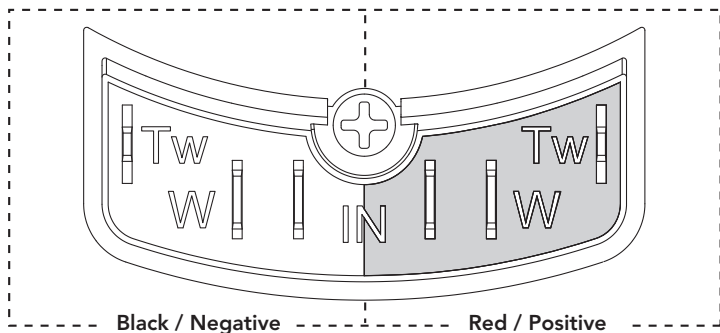

Changing from Coaxial to Separate Components: The 3.69C factory configuration is coaxial. To change configuration to separate components follow these steps:

- 1- Unplug the tweeter wires from crossover network (Fig 1).
- 2- Unscrew the long back screw with T20 Torx screwdriver and remove it completely (Fig. 2). These screws will be not used on separate system, but can be saved for go back to previous setting.
- 3- Remove the back cup cover (Fig. 3).
- 4- Pull up the tweeter wires in vertical position and remove the entire tweeter and tweeter holder from the center of woofer (Fig. 4).
- 5- Now instead of the tweeter holder insert the ABS plug (Fig. 5).
- 6- Put the rear cup back (note the two pins must be located on two slots on side wall) and secure everything with the (short) M4x8 mm screw (Fig 6).
- 7- Tweeter: with a small slotted screwdriver remove the three rubber rings (o-rings) starting from the closest to the tweeter to the farthest. The screwdriver must be inserted on dedicated slot located opposite the tweeter cables (Fig 7).
- 8- Lift the cables from the slots where they are inserted and gently remove the tweeter by pulling and turning slightly. Route the cables through the slot on the holder (Fig 8).

At this point the tweeter can be used separately with one of the supplied accessories. Refer to 3.25 installation manual. 3.165C is shown in the drawings, the procedure is the same for 3.69C.

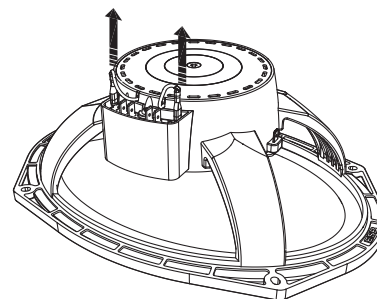

Fig. 1

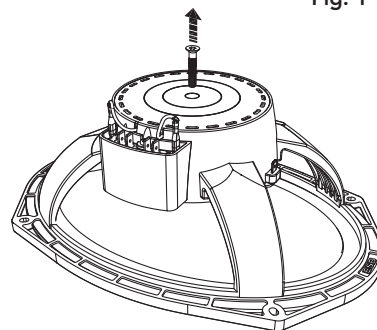

Fig. 2

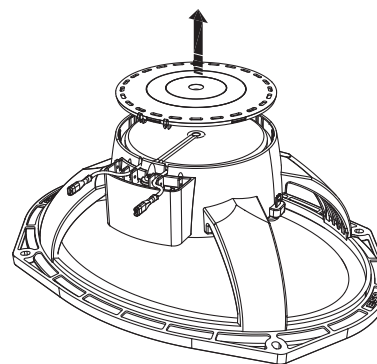

Fig. 3

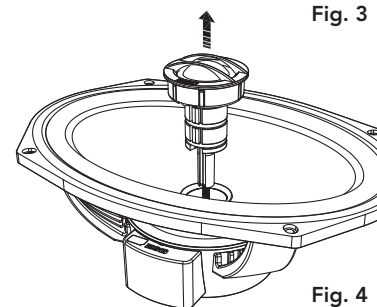

Fig. 4

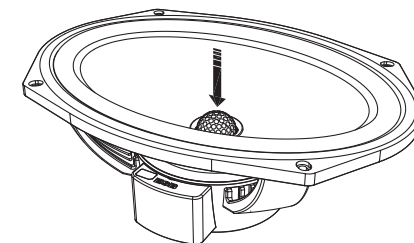

Fig. 5

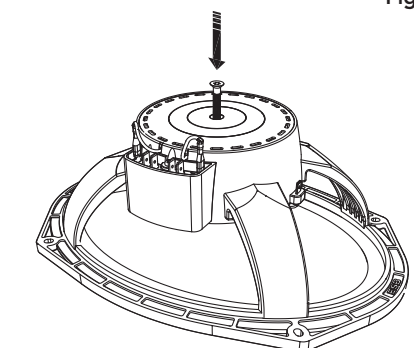

Fig. 6

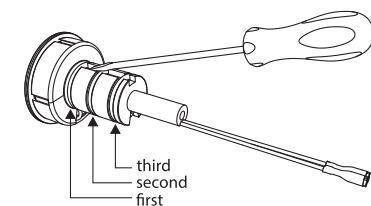

Fig. 7

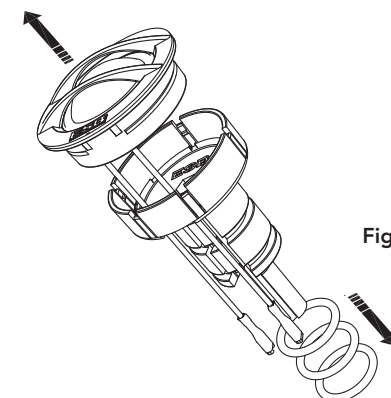
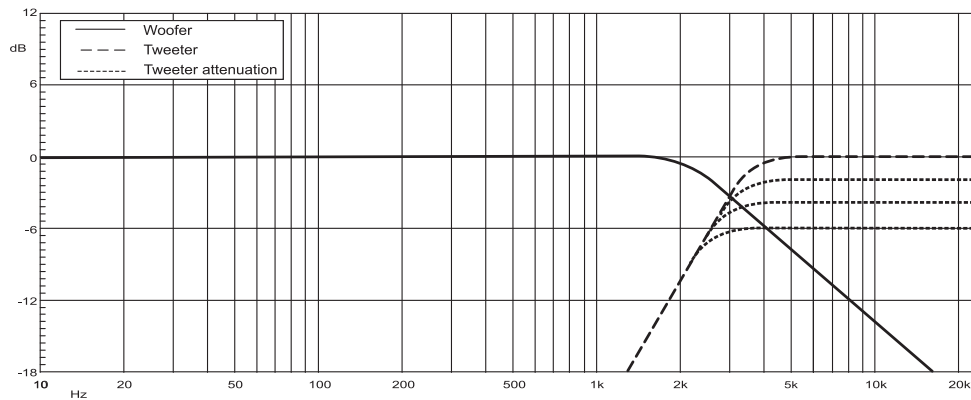

Fig. 8



ESB
AUDIO

3.6K2CX

2-Way Passive Crossover

Installation Manual

MAIN FEATURES

- Dedicated to 3000 series speakers
- Large screw terminal
- Ventilated case
- High thickness PCB copper
- 4 step tweeter level adjustment
- Secure screw cover fixing
- Clean mounting system
- Oversize not inductive ceramic resistors
- Polyester tweeter capacitor
- Asymmetrical cutting slope
- In air tweeter and midrange inductor

TECHNICAL SPECIFICATIONS

- Power handling:
300 W peak, 150 W continuous
- Crossover cut-off:
3000 Hz
- Slope:
Low-Pass 6 dB/Oct.
High-Pass 12 dB/Oct.
- Size:
104 (L) x 63 (W) x 27 (H) mm

NOTE: Make sure that your mounting location will not cause damage to the components of your vehicle. Check for airbag system location, this crossover can't be located over or close it. Never connect with different speakers than suggested, this can damage them. Never play the system with amplifier in clipping or high distortion level.

TREMILA

esbcar.com

The crossover should be installed in a dry location inside your vehicle. It can be screwed into a solid surface via all 4 holes located under the protective cover of the case. To access these holes, remove the 4 Allen screws and pull the cover away from the base. Use flat head screws type. Don't use wood screws, these use a conical head and can crack the screw holder on crossover base. Screw it by hand with limited torque when close. Don't cover the crossover case, to work well the crossover must dispose of the heat generated by the internal resistors, especially if amplifiers with power greater than 1/4 of the crossover power handling. Excessive heat build-up from closing the ventilation holes can cause damage.

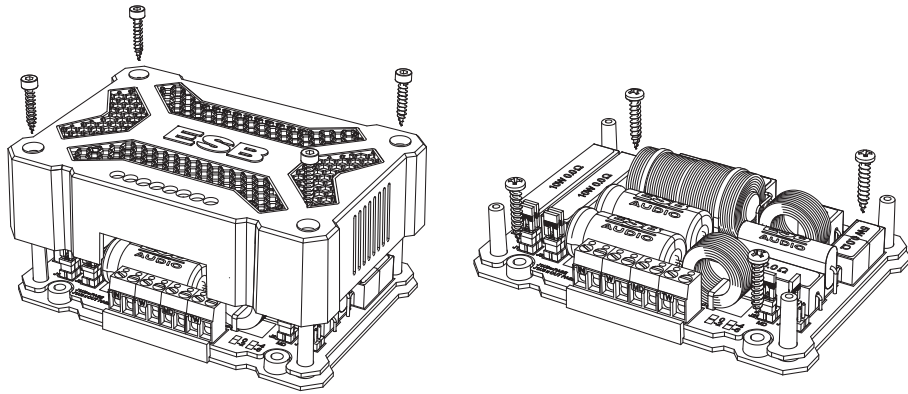

Your 3.6K2 crossover network can drive several ESB 3000 series components, follow the samples below for chose your right system combination. Your component system must be connected as shown in this manual, otherwise it may cause damage to speakers NOT covered by warranty. Do not use different crossover networks or speakers, this crossover is specially designed for 3000 series speakers.

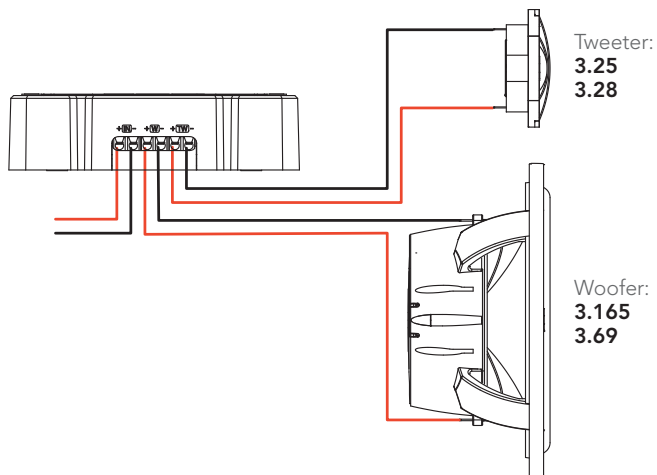

CROSSOVER NETWORK ADJUSTMENT

The **tweeter level** can be adjusted on 4 steps by first jumper on right side. The jumper allows 4 different positions that corresponds to a specify attenuation:

**Right: 0 dB, Down: - 2 dB,
Left: - 4 dB, Up: - 6 dB**

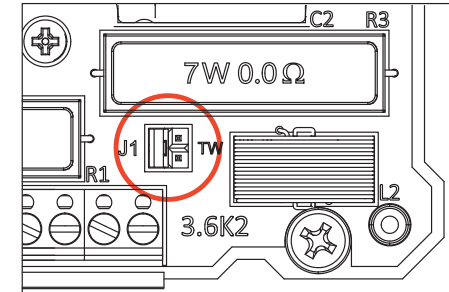

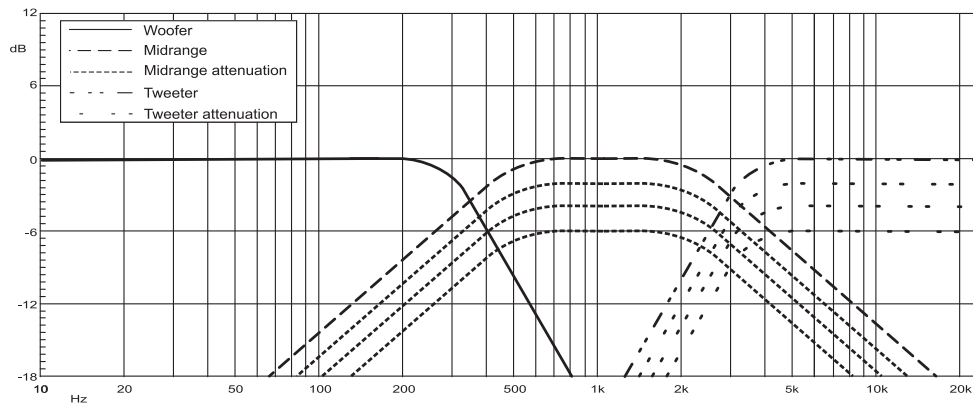

ESB
AUDIO

3.6K3CX

3-Way Passive Crossover

Installation Manual

MAIN FEATURES

- Dedicated to 3000 series speakers
- Large screw terminal
- Ventilated case
- High thickness PCB copper
- 4 step tweeter level adjustment
- 4 step midrange level adjustment
- Phase tweeter/mid. adjustment
- Secure screw cover fixing
- Clean mounting system
- Oversize not inductive ceramic resistors
- Polyester tweeter capacitor
- Asymmetrical cutting slope
- In air tweeter and midrange inductor

TECHNICAL SPECIFICATIONS

- Power handling:
300 W peak, 150 W continuous
- Crossover cut-off:
350 / 3000 Hz
- Slope:
Low-Pass 12 dB/Oct.
Band-Pass 6-6 dB/Oct.
High-Pass 12 dB/Oct.
- Size:
121 (L) x 83 (W) x 31 (H) mm

NOTE: Make sure that your mounting location will not cause damage to the components of your vehicle. Check for airbag system location, this crossover can't be located over or close it. Never connect with different speakers than suggested, this can damage them. Never play the system with amplifier in clipping or high distortion level.

TREMILA

esbcar.com

The crossover should be installed in a dry location inside your vehicle. It can be screwed into a solid surface via all 4 holes located under the protective cover of the case. To access these holes, remove the 4 Allen screws and pull the cover away from the base. Use flat head screws type. Don't use wood screws, these use a conical head and can crack the screw holder on crossover base. Screw it by hand with limited torque when close. Don't cover the crossover case, to work well the crossover must dispose of the heat generated by the internal resistors, especially if amplifiers with power greater than 1/4 of the crossover power handling. Excessive heat build-up from closing the ventilation holes can cause damage.

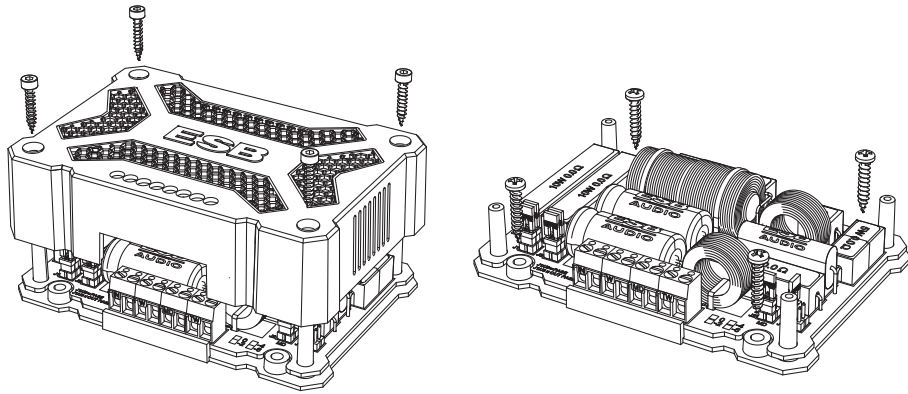

Your 3.6K3 crossover network can drive several ESB 3000 series components, follow the samples below for chose your right system combination. Your component system must be connected as shown in this manual, otherwise it may cause damage to speakers NOT covered by warranty. Do not use different crossover networks or speakers, this crossover is specially designed for 3000 series speakers.

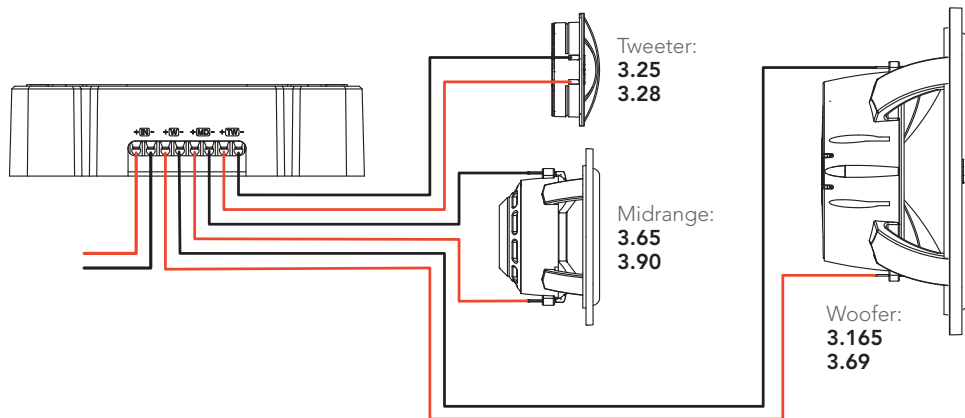

CROSSOVER NETWORK ADJUSTMENT

The **midrange level** can be adjusted on 4 steps by first jumper on right side. The jumper allows 4 different positions that corresponds to a specify attenuation:

**Right: 0 dB, Down: - 2 dB,
Left: - 4 dB, Up: - 6 dB**

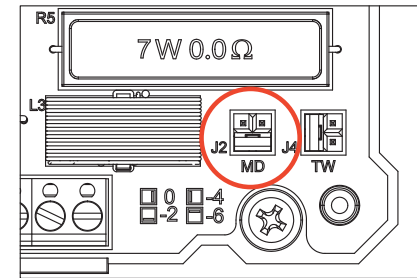

The **tweeter level** can be adjusted on 4 steps by first jumper on right side. The jumper allows 4 different positions that corresponds to a specify attenuation:

**Right: 0 dB, Down: - 2 dB,
Left: - 4 dB, Up: - 6 dB**

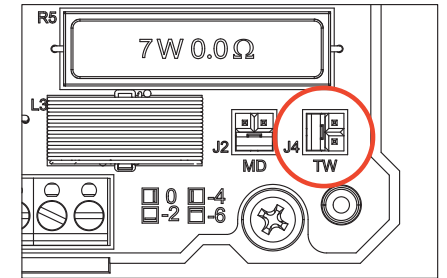

The **midrange phase** can be adjusted on 2 steps by first jumper on left side. The jumper allows 2 different positions that corresponds to a specify phase set up:

**All jumper Horizontal: PHASE = 0°
All jumper Vertical: PHASE = 180°**

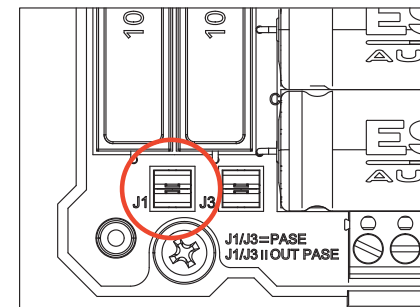

The **tweeter phase** can be adjusted on 2 steps by second jumper on left side. The jumper allows 2 different positions that corresponds to a specify phase set up:

**All jumper Horizontal: PHASE = 0°
All jumper Vertical: PHASE = 180°**

